



## PRODUCT PROFILE:

# VECTOR LATCHES

THE ULTIMATE FAMILY OF MULTI-POINT LATCHING

## WORLDWIDE ACCESS EXPERTS

Allegis is the world expert in supplying access hardware that secures and protects enclosures for work and service vehicles, heavy equipment, HVAC, telecommunications and electrical cabinets, power generation and more. We started in the truck and transportation business in 1969. Since then, no one knows more about how to combine all of the right components — latches, handles, hinges, gaskets, and gas springs — to increase productivity, enhance ease of access, and reduce manufacturing and maintenance costs. Based in the U.S., Allegis works with manufacturers worldwide, from start-ups to Fortune 100 manufacturers to help them make their products better.



## VECTOR: THE SUITABLE SOLUTION

The **VECTOR™** latching system was designed for those who needed an updated design and better functionality. The exterior of these latches and handles are designed to be flush mounted with recessed latching for multiple applications. The robust design, vibration resistance, quality materials, and multiple functions, are what make the **VECTOR™** latching system stand out above all the rest.

## THE ORIGINATOR: VECTOR T-HANDLE

The compression of the flush fitting **VECTOR™** T-handle, seals out snow, rain, and dust. The sturdy T-handle is ideal for operating in rugged environments or with gloved hands. The handle has optional locking methods; either padlockable, cylinder lock or non-locking. The fiber-glass reinforced polyamide handle rotates 90° right, 90° left or 180°. The T-handle offers versatile mounting options. It can be secured with either screws, rivets or cast-in bolts.

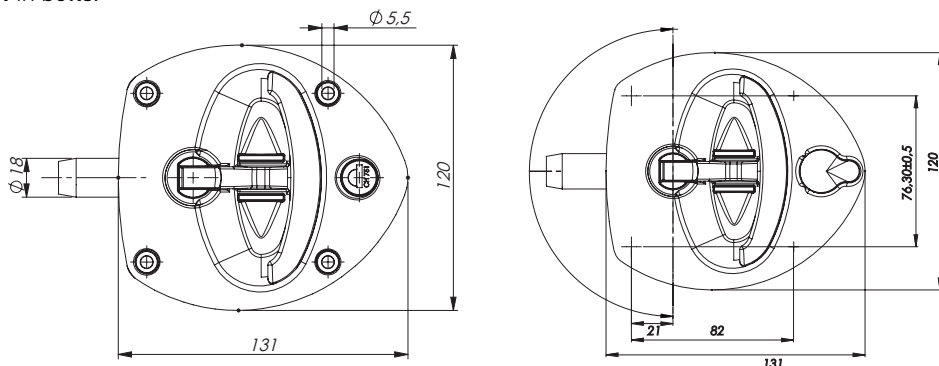

## THE NEXT GENERATION: VECTOR 2 T-HANDLE

In contrast to the 1st generation **VECTOR™** T-handle, has an updated styling that sets your truck or work box apart from the competition. The **VECTOR™ 2** offers different handle finishes, similar to its predecessor, chrome or black powder coat. The noticeable design change is the new pour in place gasket and a two screw mounting bracket for easy installation. Whether you are looking for single or multi-point latching, this T-handle offers an adjustable or fixed cam. The **VECTOR™ 2** meets all requirements with its more robust design.

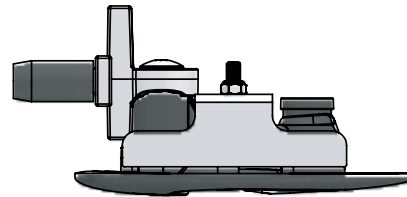
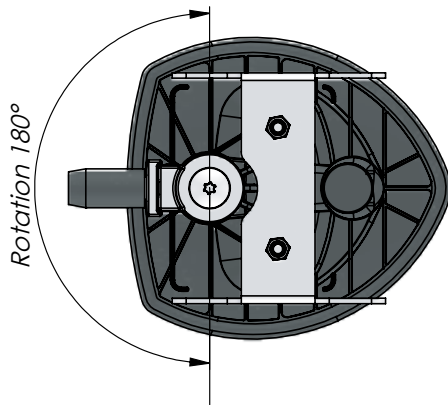

## APPLYING OUR INDUSTRY EXPERTISE

With over 50 years of experience, Allegis application engineers work closely with a manufacturer's design engineers to develop various options to determine the best latching system. The **VECTOR™** latches not only suit the needs of our customers, they are durable for all weather conditions, and have that aesthetic look that our customers like. These T-handles were designed to suit the needs of the many industries including:

- Agricultural Equipment
- Power Generation
- Service Trucks
- Buses
- Construction Equipment
- Emergency Vehicles
- Storage Boxes

## CREATING A BETTER END PRODUCT

Ready to begin your next project? For answers about latching systems and other access hardware, contact Allegis. Let our application engineers help your organization think through options that will drive more value and a better product experience for the end-user.



**CALL US AT 866.378.7550**

VISIT [ALLEGISCORP.COM](http://ALLEGISCORP.COM)

OR EMAIL US AT [ACCESSBETTERTHINKING@ALLEGISCORP.COM](mailto:ACCESSBETTERTHINKING@ALLEGISCORP.COM)

