



The Vision System



ALLEGIS

A CUSTOMER DRIVEN COMPANY

Vision Outside Rod Latch System

- Suitable in applications where the end user is looking to maximize internal cabinet space
- Mounted outside the sealing area without any intrusion to the interior of the cabinet
- Control mechanism, rod guides and compression plates mount to the door while the latch points are mounted on the frame
- Door opens and closes from the movement of the swing handle due to a gear inside the control mechanism that moves the flat rod upwards or downwards

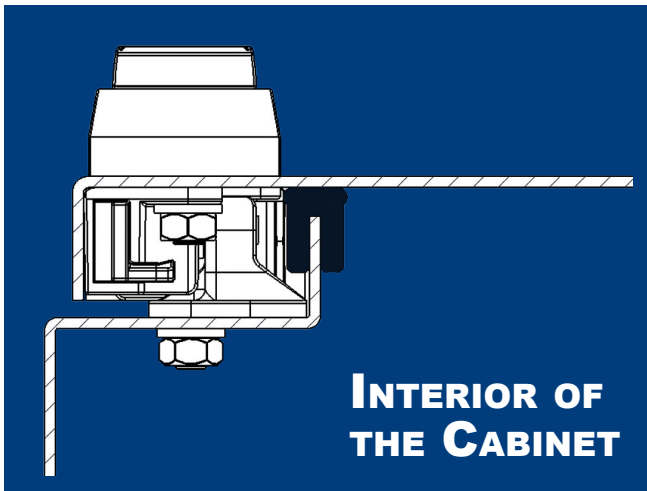

Choice of Material:

Control Mechanism Housing: zinc die-cast, fzb or AC4605

Gear: acid proof stainless steel

Spring: stainless steel

Rod Guide: zink die-cast, fzb or AC4605

Compression Plate: zink die-cast, fzb or AC4605

Latch Point Base: zink die-cast, fzb or AC4605

Rivet: steel, fzb or acid proof stainless steel

Rollers: brass, nickel plated

Rod: mild steel, fzb or acid proof stainless steel



Design Advantages

DOOR

FRAME

LATCH POINT

- The only “outside” rod latch system on the market that eliminates door sag due to weight and the hinge’s inability to hold for twisting forces, i.e. torque.
- Door meets the gasket without any side load and is perfectly aligned before any compression is initiated resulting in a better seal and less wear on the gasket.
- Rod guide and latch point are located at the same height on the Y-axis. When the door is locked, all force is directly transferred from the door to the frame. The flat rod is completely unloaded and will not be subjected to any twisting forces and the door will not flex. The resulting solution provides an equally compressed gasket along the entire length of the door.
- Symmetric cabinet design – latch points and rod guides have the same cutouts as the frame parts and door parts of the Click Hinge.

LATCH POINT BASE

FLAT ROD

ROD GUIDE

COMPRESSION PLATE

Vision Inside Rod Latch System

Choice of Material:

Control Mechanism Housing: zink die-cast, fzb

Gear: acid proof stainless steel

Spring: stainless steel

Latch Point Housing: acetal polymer

Roller Cam: Mild steel, fzb

Roller: glass reinforced polyamide

Rivet: steel, fzb

Bolt: zinc die-cast, fzb

Rod: mild steel, fzb

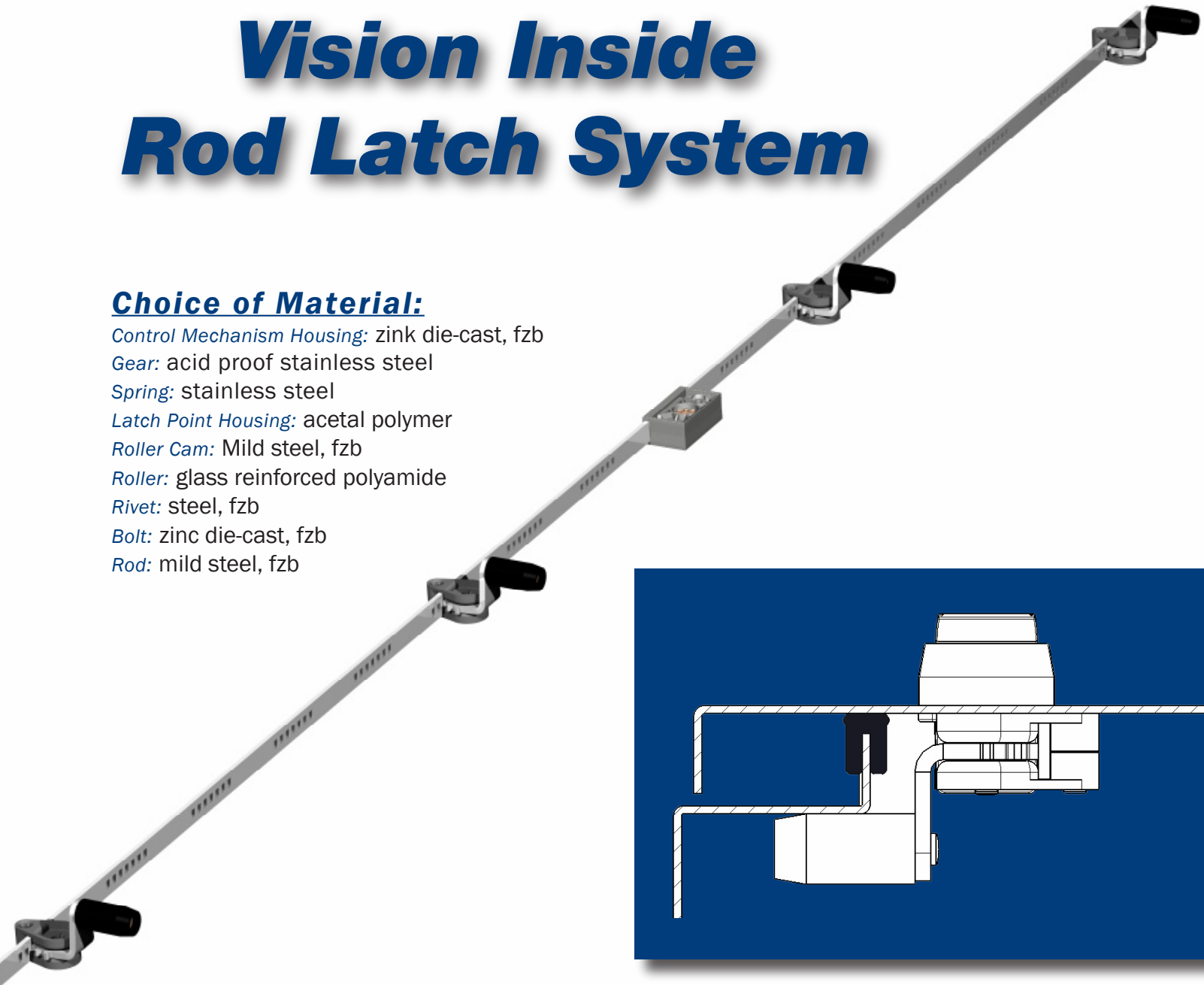

- *Used when easy and fast mounting is the highest priority*
- *Requires some space inside the cabinet interior*
- *Mounts on the door and there are no loose parts*
- *Door opens and closes from the movement of the swing handle due to a gear inside the control mechanism that moves the flat rod upwards or downwards*

Perfect Sealing with Vision Inside

The Vision Inside latch point has multiple functions. The latch point housing holds together all the components and at the same time it performs as a rod guide as well. The most important feature is that the torque caused by the sealing force is handled by the base of this latch point. The flat rod is completely unloaded. The flat rod will not twist or bend. All of the movement happens within the latch point. The door does not flex when it is locked which makes the gasket equally compressed along the entire length of the door.

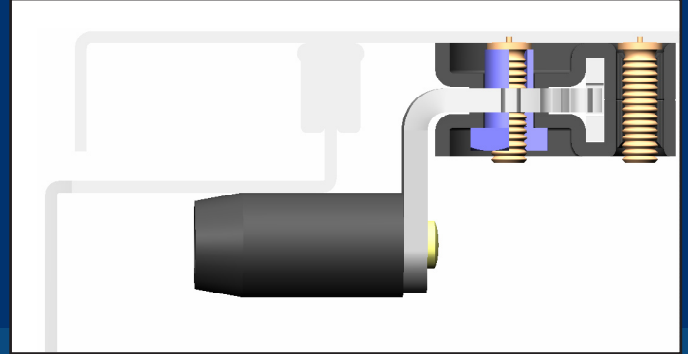

The flat rod in the Vision Inside system moves downwards at closing. The downward movement prevents failure because gravity will tend to keep the system locked.

The flat rod is exactly the same rod as in the Vision Outside system.



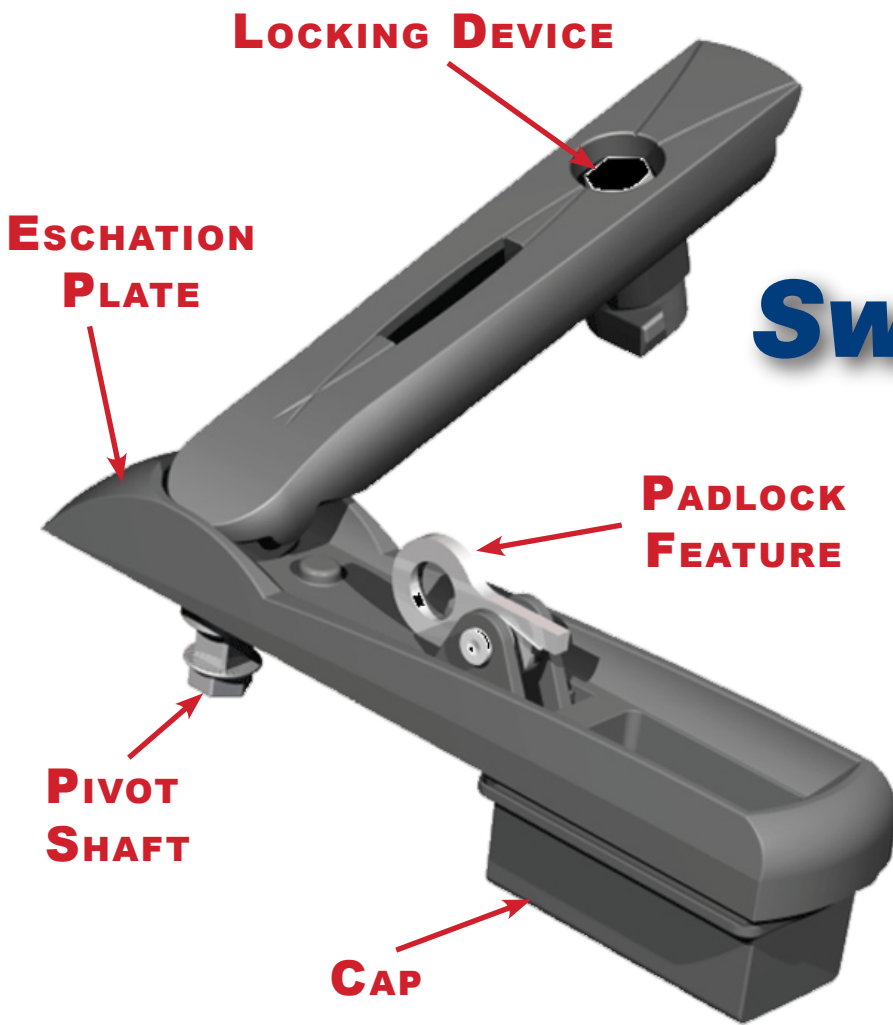

Swing Handle

Choice of Material:

Die cast zinc
Acid proof stainless steel
Die cast zinc AC4605, fzb
Glass reinforced polyamide base tray
Black powder coated finish

- *Clean, modern appearance that signals strength and reliability*
- *Used in both Vision Inside and Vision Outside systems*
- *Operated by a lift and turn motion*
- *Designed for both right and left hand mounting*
- *Available in a “slam-to-latch” or “quarter-turn to latch” configuration*
- *Tool operated or key-locking*
- *Optional padlock feature for additional security – spring loaded padlock loop retracts when the handle is opened, allowing the user to get a good grip around the handle while also minimizing the risk of hand injury.*
- *IP65/NEMA 4 compliant*

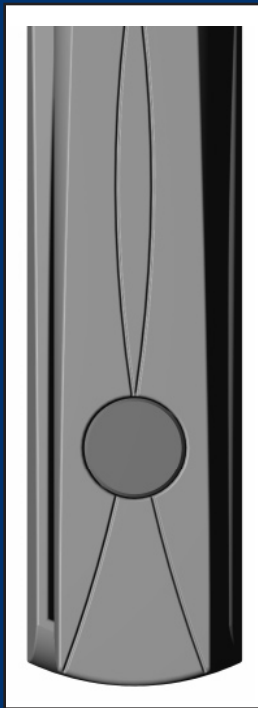

BLIND PLUG

*Push-to-Open
Slam-to-Latch*



INSERT

*Operated by a quarter-turn key
Quarter Turn Turn-to-Latch
Slam-to Latch
Padlockable or not*

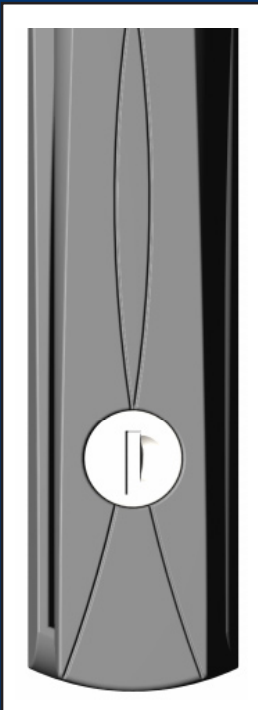

BARREL

*Key options:
IL1333 keyed like
KT keyed to differ
Slam-to-Latch
Padlockable or not*

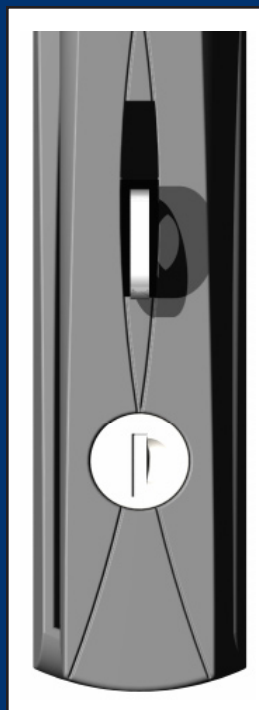

PROFILE CYLINDER

*Key Operated
Turn-to-Latch
Dustcover*

Click Hinge

- *Revolutionary, uniquely designed concealed hinge saves time and effort during door installation*
- *Self-locking and pull out door removal functions*
- *120 degree opening angle*
- *Universal left and right hand configuration*
- *Safety slider prevents the over-center latching mechanism from turning back and disengaging the door when it opens and closes*

- *When removing the door, the safety slider is pulled back by hand, the over-center latch is turned by hand or screw driver and the door is removed*
- *Single brass washer on the pin allows the door and frame part to move against each other without damaging the surface treatments*
- *Hinge pin is riveted to the frame to provide long term reliability*

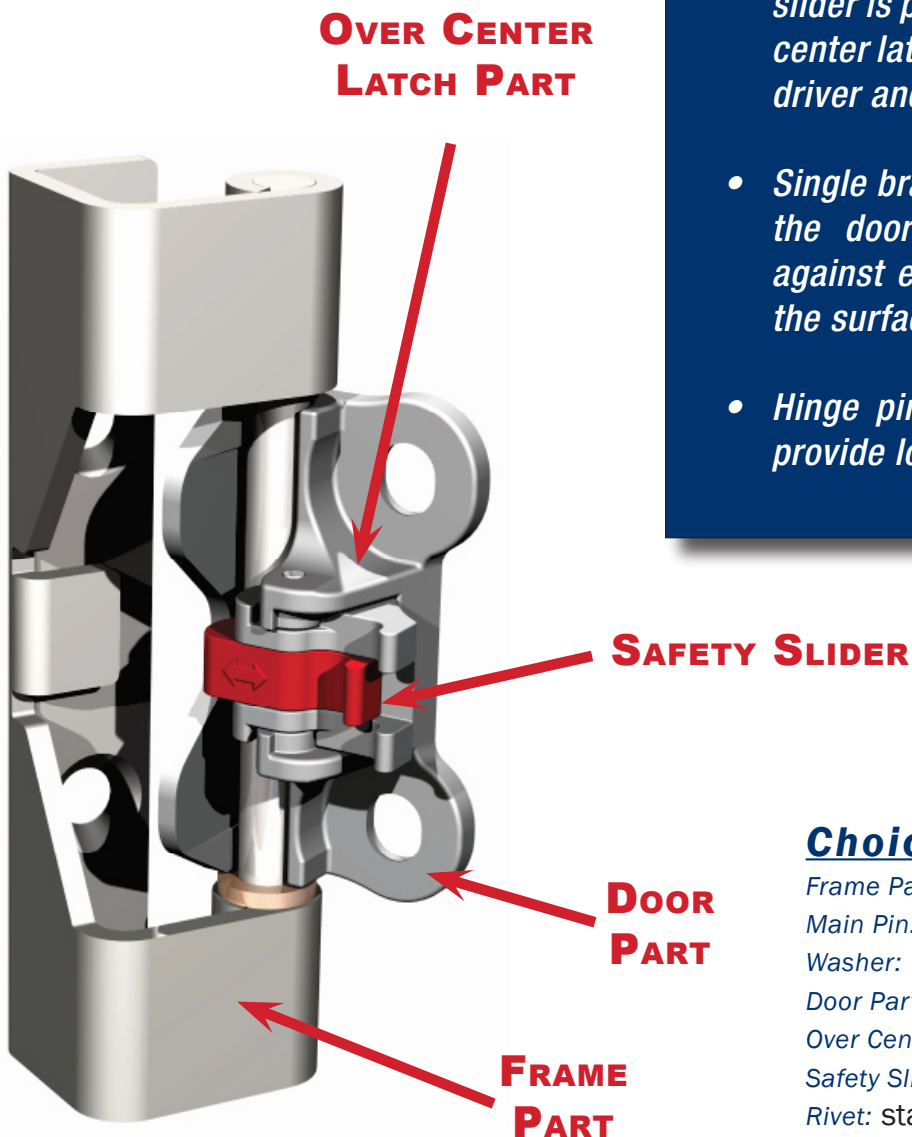

Choice of Material:

Frame Part: mild steel, fzb or stainless steel, AC406

Main Pin: stainless steel or acid proof stainless steel

Washer: brass, nickel plated

Door Part: zinc die-cast, fzb or AC406

Over Center Latch Part: zinc die-cast, fzb or AC406

Safety Slider: polyamide

Rivet: stainless steel or acid proof stainless steel

Mounts on the Door

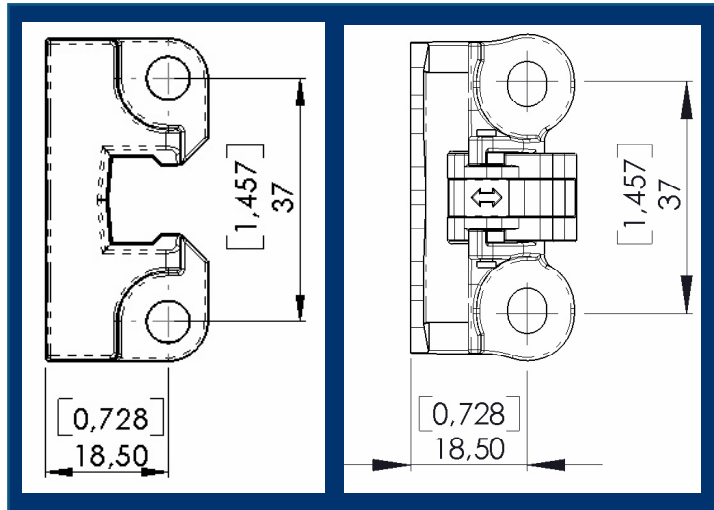
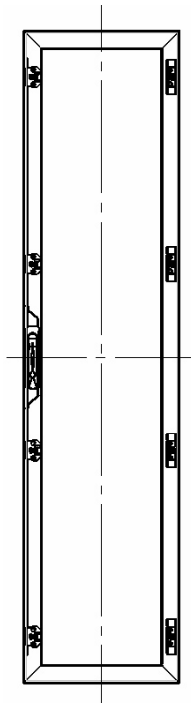

Vision Rod Guide

ClickHinge Door Part

The Vision Outside system latch points and rod guides have the same cut-outs as the frame parts and doorparts of the ClickHinge. The cabinet design becomes symmetric by designing the hinge and latch points with the same cut outs.

This means that every frame and door has the same cut-outs on their long sides regardless of what side the door is going to be hinged from. The hinge and rod latch system mount the same way on each door. When it is time to install the door onto the frame, the door itself is turned right and hung onto each hinge frame part.

The handle is assembled together with the control mechanism containing the additional rod and the system is defined as right or left mounted.

This just-in-time installation system makes the production very flexible and protected from potential operator assembly errors.

Mounts on the Frame

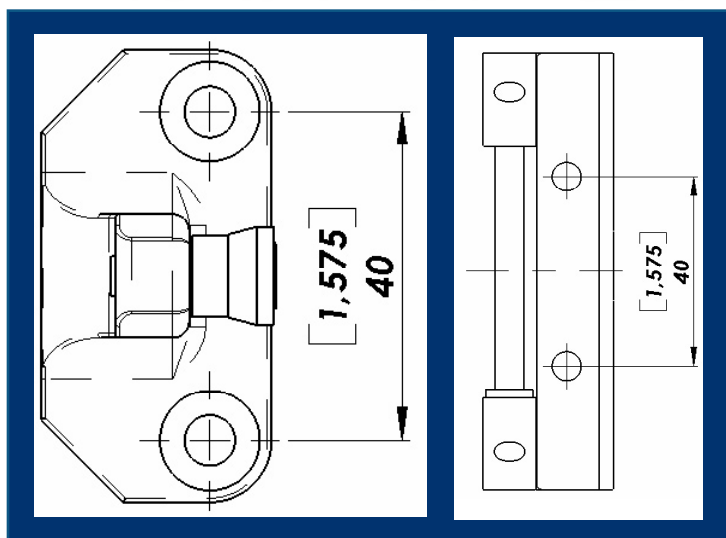

Vision Latch Point

ClickHinge
Frame Part

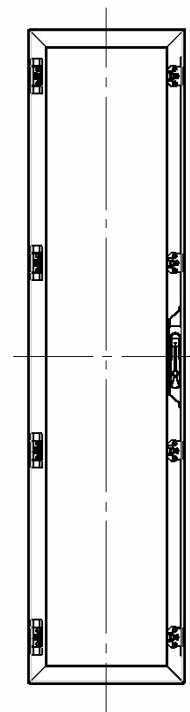

Corrosion Resistance



GR-487-CORE requirement: "All cabinet components shall be resistant to corrosion and all mechanical (e.g., cabinet surfaces, gaskets, seals, hinges, locking mechanisms, door alignment and restrainers) shall continue to function and operate satisfactorily after exposure to salt fog for 30 days."

Rod latch systems and hinges designed for mounting outside the sealed area of a cabinet are constantly exposed to the elements. Today, we are able to provide our costumers with a system that copes with salt water, high humidity, a tough urban environment and other similar climate strains.

Vision Outside rod latch system, Vision swing handle and ClickHinge exceed 30 day salt-fog testing per GR-487-Core. In order to meet the requirement above, a lot of effort was put in finding right materials and surface treatments for each component of these three products.

Therefore, the components subjected to stress are manufactured from acid proof stainless steel, brass and zinc. The zinc parts have a high quality surface treatment that resists at least 30 days in salt fog.

On the other hand, components that are less subjected to stress uses glass reinforced polyamide as material in order to optimize performance and appearance.

Torque

GR-487-CORE (R3-66): "The door locking hardware and mechanism shall be capable of withstanding anticipated torque levels, without physical distortion, damage, or loss of functionality."

Test Procedure - A torque of 400 in-lbs minimum shall be applied to the door opening hardware by means of the manufacturer specified tool and a commercially available torque tester, and be maintained for a minimum of 5 seconds and then released. This procedure shall be repeated a total of 10 times."

THE PIVOT SHAFT

The Pivot Shaft of the handle is made of die-cast zinc. Its lower edge is designed with a square boss and eight cogs around it.

The cogs are connected to the control mechanism gear by a equivalent square hole and the cogs mesh together.

By having this compact joining between the pivot shaft and the gear, a wider load distribution in the pivot shaft is achieved and it's torsional strength exceeds 450 inch pounds (50Nm) of torque.



THE INSERT

The Insert is made of acid proof investment -cast stainless steel, which provides superior strength. The insert exceeds 400 inch pounds (45Nm) in torque when it is rotated.



Earthquake Proof

Vision Outside Highlander system together with Vision Highlander swing handle and ClickHinge Highlander have been installed on an enclosure and subjected to the VERTEQII earthquake synthesized waveform testing at the highest acceleration level Risk Zone 4. discreet frequencies and aplitudes for the Required Responce Spectrum (RRS) were as follows:

Frequency (Hertz)	Acceleration (g-peak)
0.3	0.2
0.6	2.0
2.0	5.0
5.0	5.0
15.0	1.6
50.0	1.6

Upon completion, these products sustained no permanent structural or mechanical damage and the test items met applicable mechanical operation requirements immediately before, and after each axis of waveform testing.

The Vision System Advantage

- *Reduced door flex which provides uniform compression over the gaskets entire length*
- *No wear on the gasket*
- *No dislocation between latch points, i.e. the door is always equally locked along its whole length*
- *Excellent flexibility*
- *Door can be locked by a rod going downwards*
- *Vision Outside combined with Click Hinge gives a symmetric cabinet design*
- *Vision Swing Handle is available in slam-to-latch or quarter-turn to latch versions*
- *Handle has a clean, modern appearance, numerous locking options and an innovative padlock feature that enhances performance and safety*
- *Handle meets IP65/NEMA 4 sealing classification*
- *Upgradeable to a system with corrosion resistant materials for long term reliability and performance in the most demanding outdoor environments*
- *These upgraded systems exceed 30 day salt fog testing and are GR-63 compliant for seismic conditions*
- *Handle with stainless steel knuckle upgrade holds for 45Nm or 400 inch pounds of torque*