

APPROVAL - CUSTOMER NAME & SIGNATURE

DATE

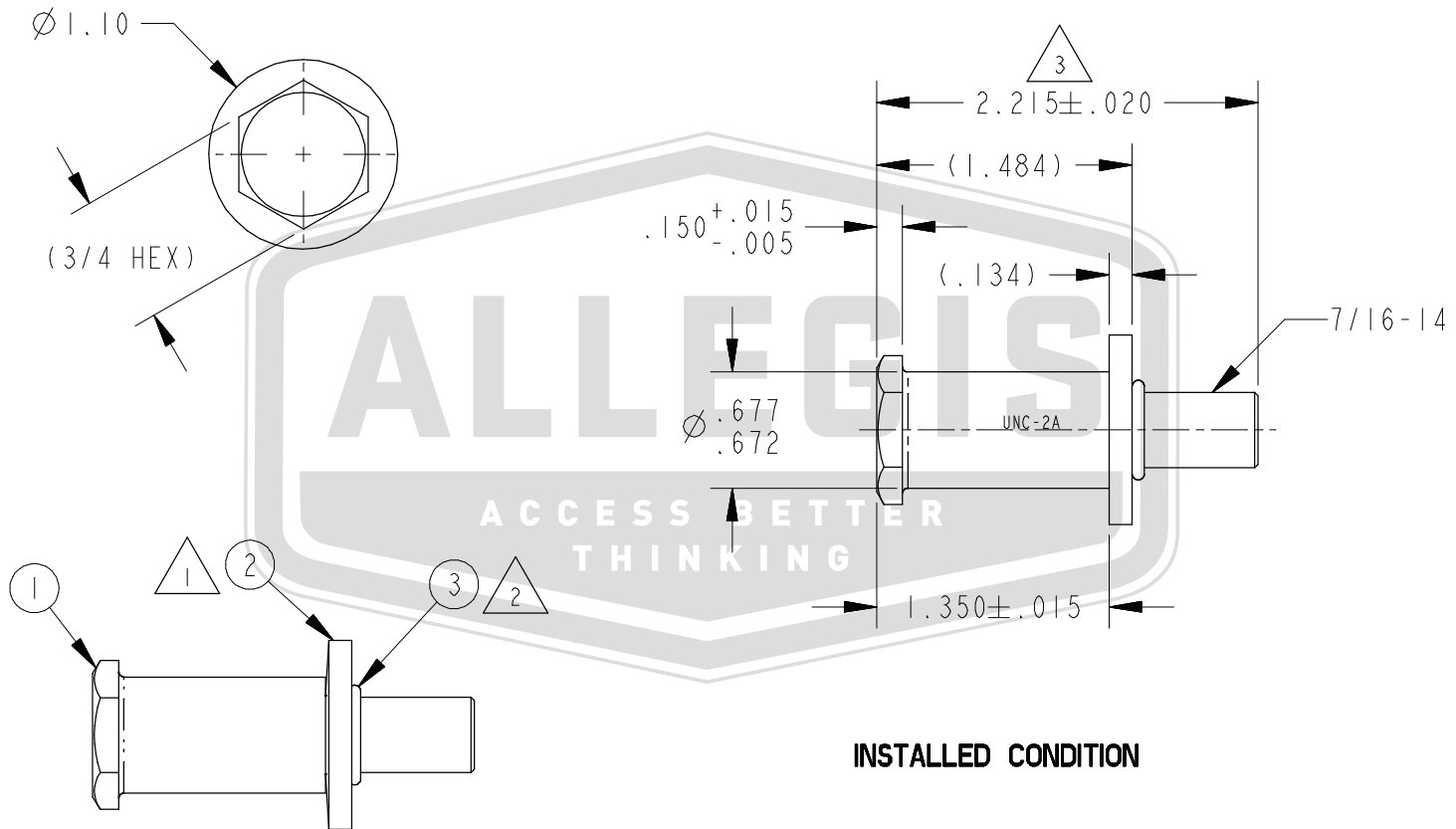

UNINSTALLED CONDITION

INSTALLED CONDITION

ALLEGIS		1-866-378-7550
MATERIAL:	Steel	DRAWING NO. : 10338-16
FINISH:	Zinc Plate, yellow chromate	
REV.:	1:2	DATE: 8-3-2023

- 1 WASHER (ITEM 2) ORIENTATION IMPORTANT.
- 2 FUNCTION OF O-RING (ITEM 3) (LOCATED APPROXIMATELY AS SHOWN) IS TO RETAIN THE WASHER UNTIL THE STRIKER BOLT IS INSTALLED.
- 3 DIMENSION INDICATES BLANK SIZE PRIOR TO ROLLING THREADS.
- 4. PLATED THREADS TO BE INSPECTED WITH A 7/16-14 3A GO RING GAUGE.
- 5. INSTALLATION TORQUE 56 FT-LBS MINIMUM DEPENDING UPON SURFACE CONDITION OF THREAD.