

APPROVAL - CUSTOMER NAME & SIGNATURE

DATE

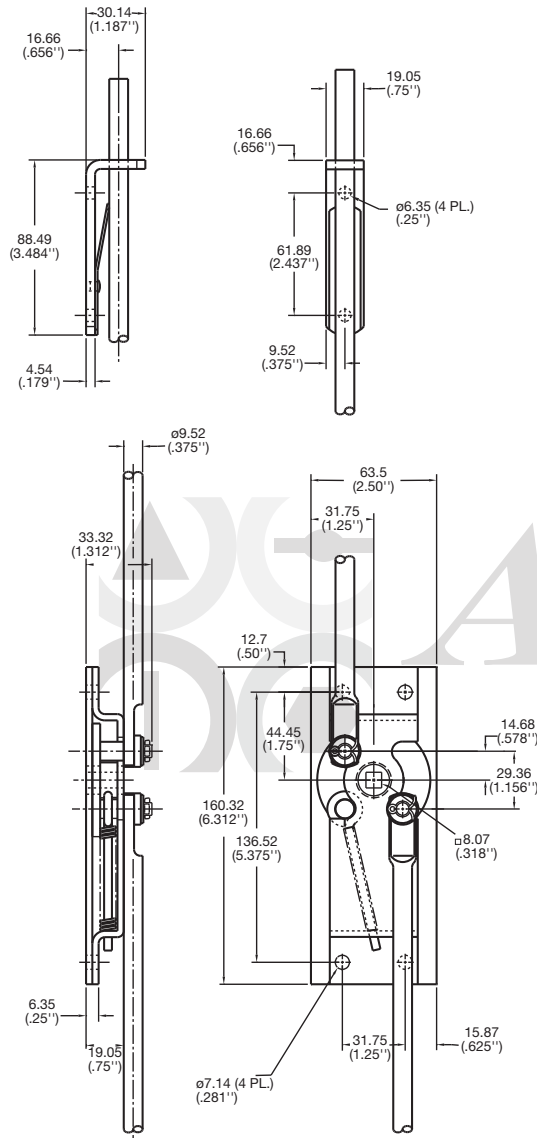

ALLEGIS CORPORATION

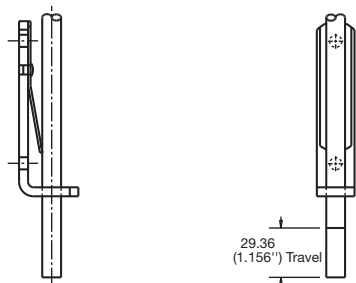

www.ALLEGISCORP.com
1-866-378-7550

MATERIAL / FINISH :
Stainless Steel or Zinc

REV. :

1 : 1

DATE :

1-11-2016

DESCRIPTION :

2-point Rod Latch

DRAWING NO. :

105-48 (SS or ZN)