

REV.	DATE	BY-CHKD	REVISIONS	ITEM	COMPONENT	PART No.	MATERIAL	FINISH
B	05 MAY 94	BMC	PRN: 19-92	ASSEMBLY		19-14-10		
C	04 JAN 95	JGK	PRN: 19-113					
D	05 MAY 95	MMM	PRN: 19-122		HANDLE		DIE CAST ZINC	SEE NOTE *B*
E	09 OCT 96	SWD	PRN: S-93-23		SHAFT		BRASS	SEE NOTE *C*
F	02 JAN 2002	DLH	PRN: P2002-0764		PIN		303 STAINLESS STEEL	SEE NOTE *A*
G	17 AUG 2016	JPK CMS	PRN: P2016-1906		BUSHING		1R/BR RUBBER	BLACK
					NUT		NYLON	BLACK
					WASHER		ACETAL	BLACK

INSTALLATION INSTRUCTIONS:

1. PREPARE A SHAPED HOLE IN DOOR OR OUTER PANEL AND A ROUND HOLE IN THE FRAME.
2. WITH HANDLE IN OPEN POSITION INSERT SHAFT THROUGH HOLE IN DOOR, THEN PASS BUSHING OVER SHAFT AND SECURE WITH NYLON NUT.
3. ADJUST NYLON NUT TO PROVIDE A SATISFACTORY HOLD IN, OR BEHIND FRAME HOLE WITH MODERATE LOCKING FORCE.

NOTE A: BLACK OXIDE COATING.
 NOTE B: BLACK POWDER COATING.
 NOTE C: ZINC PLATE, BLACK CHROMATE

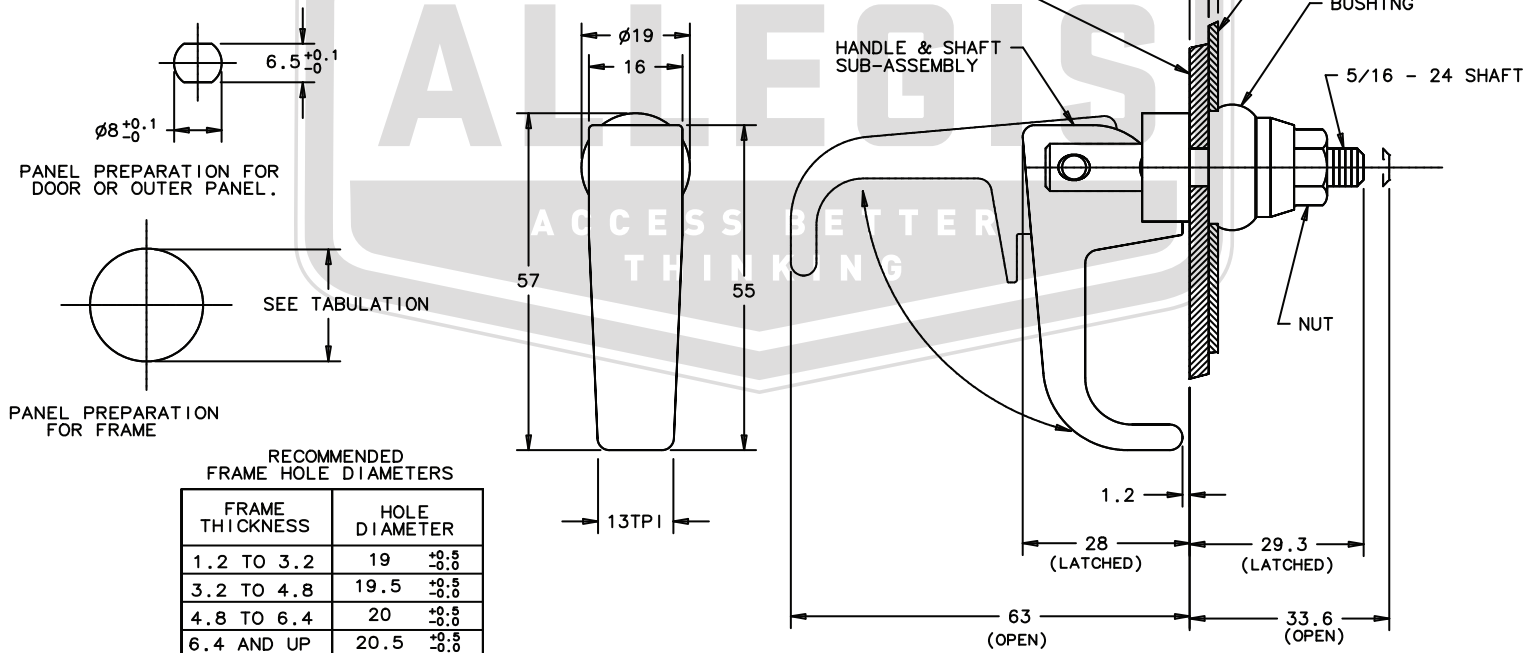

RECOMMENDED FRAME HOLE DIAMETERS

FRAME THICKNESS	HOLE DIAMETER
1.2 TO 3.2	19 ^{+0.5} / _{-0.0}
3.2 TO 4.8	19.5 ^{+0.5} / _{-0.0}
4.8 TO 6.4	20 ^{+0.5} / _{-0.0}
6.4 AND UP	20.5 ^{+0.5} / _{-0.0}

FORMAT 3/88

ALLEGIS	1-866-378-7550
MATERIAL: Zinc Alloy	DRAWING NO. : 19-14-10
FINISH: Black Powder Coat	
REV.: 1:1	DATE: 5/28/2019