

APPROVAL - CUSTOMER NAME & SIGNATURE

DATE

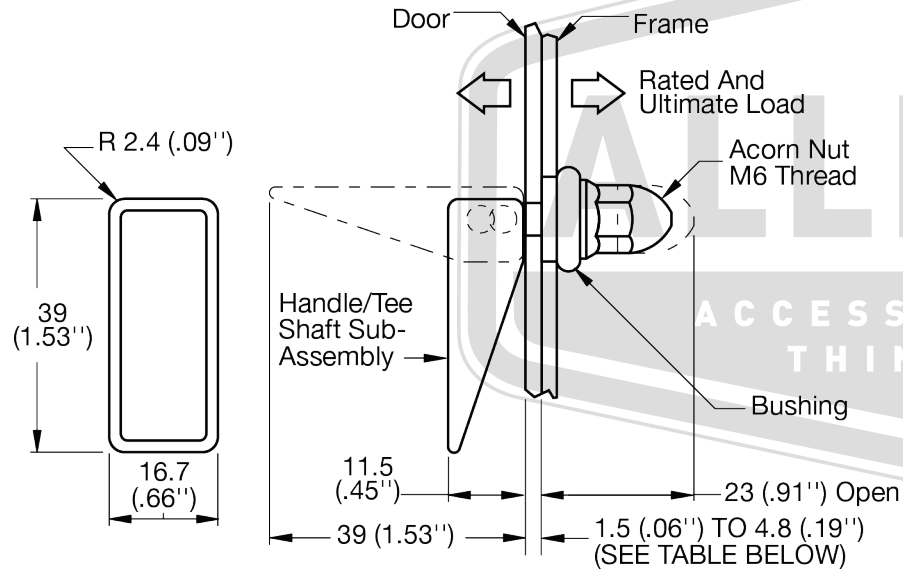
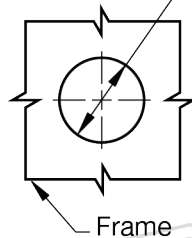
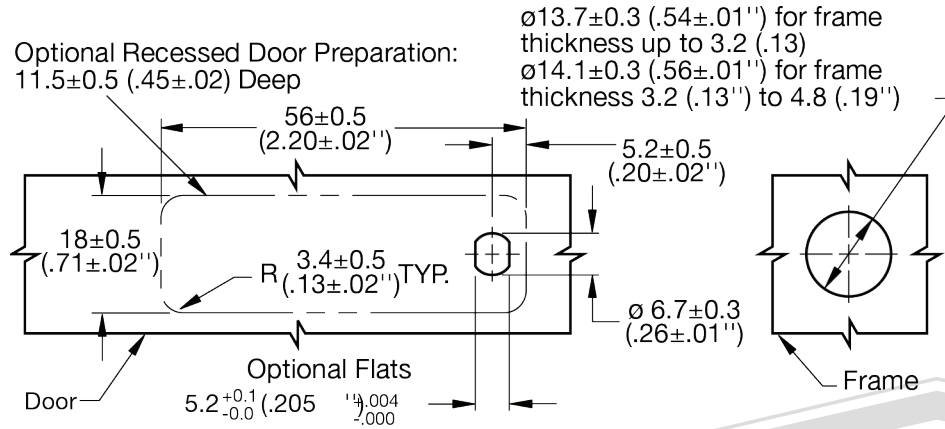

DOOR THICKNESS	USE WASHER?	ADJUSTMENT REQUIRED?
1.7±0.2 (.07±.01)	YES	NO
1.9 (.08) to 2.3 (.09)	YES	YES
2.5±0.2 (.10±.01)	NO	NO
2.7 (.11) to 4.8 (.19)	NO	YES

ALLEGIS

1-866-378-7550

MATERIAL:

DRAWING NO. :

19-54-01

FINISH:

REV.:

1:1

DATE:

6/11/2019