

APPROVAL - CUSTOMER NAME & SIGNATURE

DATE

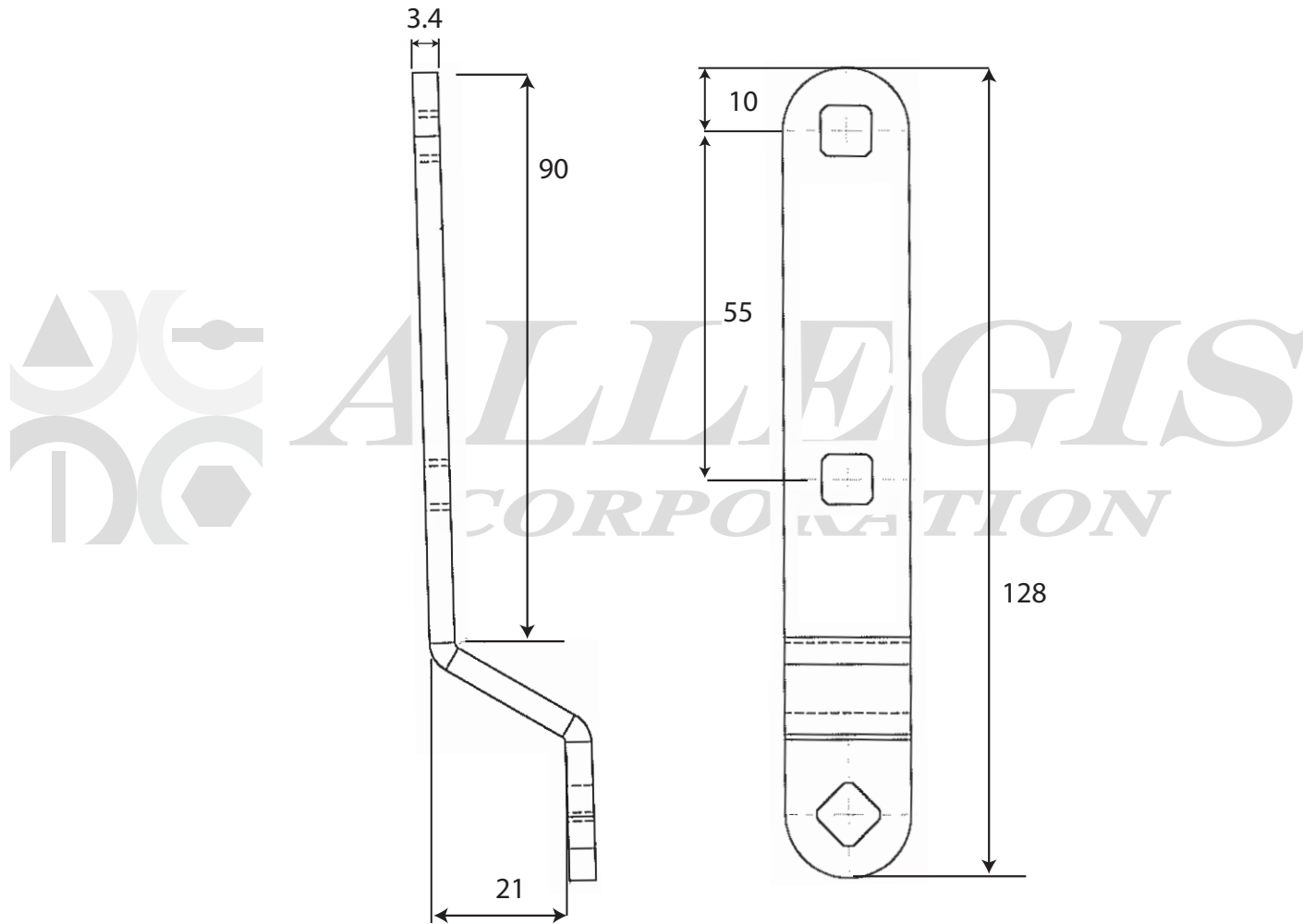

www.ALLEGISCORP.com
1-866-378-7550

MATERIAL / FINISH :
Stainless Steel

REV. :
1 : 2

DATE :
2-14-2017

DESCRIPTION :
Handle

DRAWING NO. :
265076-5001 T316