

Part Number	Slide Length	Chassis Length	Slide Travel	A	B	C	D	E	F	G
22WB	23.0 [584]	21.95 [558]	24.00 [610]	-	-	14.50 [368.3]	16.38 [416.0]	18.13 [460.4]	-	-
24WB	25.00 [635]	23.95 [608]	26.00 [660]	-	-	14.50 [368.3]	16.38 [416.0]	18.13 [460.4]	20.16 [512.0]	-
26WB	27.00 [686]	25.95 [659]	28.00 [711]	10.08 [256.0]	10.88 [276.2]	-	16.38 [416.0]	18.13 [460.4]	20.16 [512.0]	21.75 [552.5]

Detail A

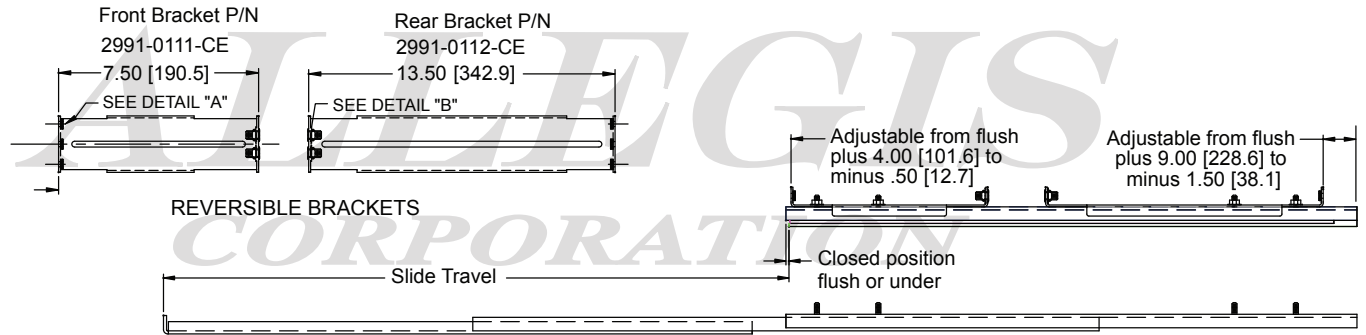

Detail B

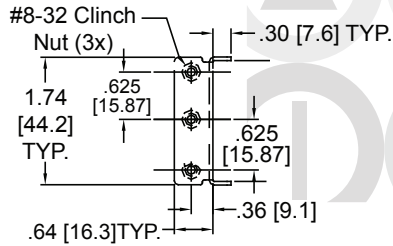
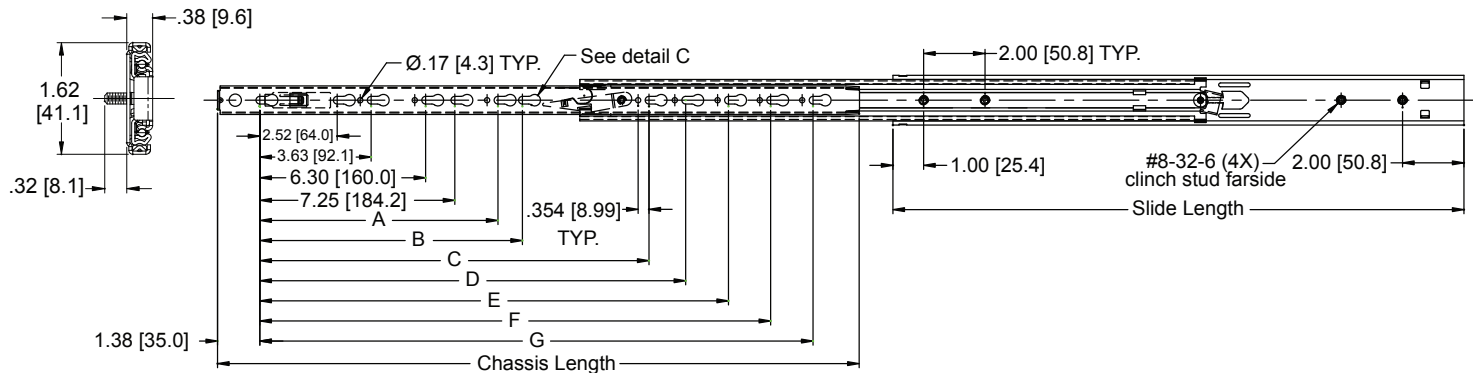
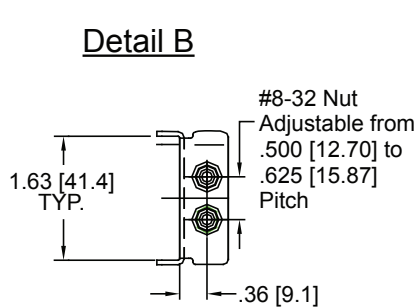

Detail C

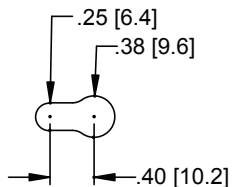

www.ALLEGISCORP.com 1-866-378-7550		MATERIAL / FINISH : Bright electro-zinc (C) plating	
REV. : 1 : 2	DATE : 2-20-2017	DESCRIPTION : Drawer Slide	DRAWING NO. : WB series (See Chart)