

APPROVAL - CUSTOMER NAME & SIGNATURE	DATE

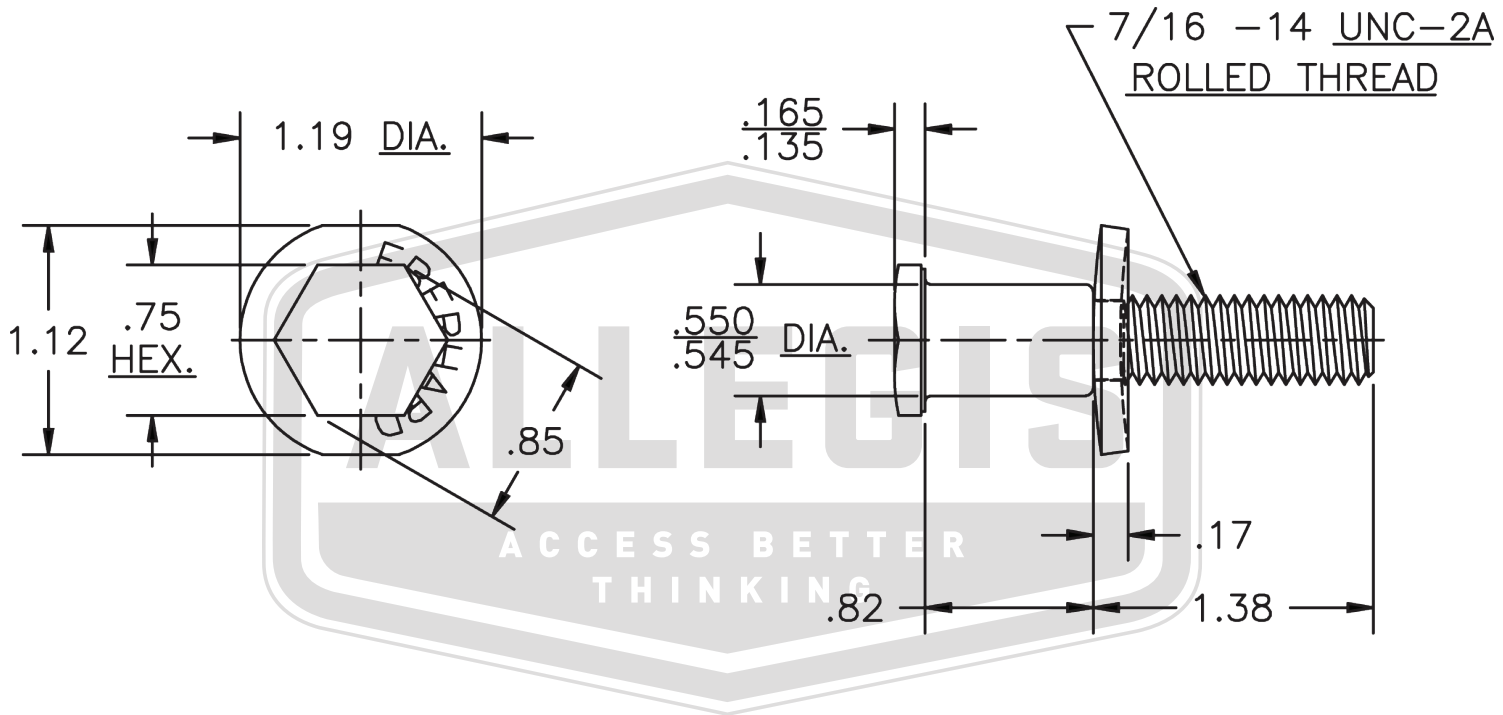

NOTES:

- 1.) MATERIAL: SAE J429, GRADE 8
- 2.) FINISH: (25) ELECTRO ZINC (.0002) AND BAKE
- 3.) INSTALLATION: TORQUE TO 45-50 FT. LBS.

ALLEGIS	1-866-378-7550
MATERIAL:	DRAWING NO. : 5-400-52 ZN
FINISH: Zinc	
REV. : 1:1	DATE: 6/12/2019