

REV	DATE	DRAWN/CHKD	DESCRIPTION	PART NUMBER	MATERIAL	FINISH
				62-10-603-XX	NOTE A	NOTE A

NOTES:

- A. HANDLE-SHAFT ASSEMBLY CONSISTS OF:
 HANDLE AND SLEEVE-DIE CAST ZINC,
 FINISHED AS:
 -10 BRIGHT CHROME PLATE
 -20 BRUSHED CHROME PLATE
 -30 CHEMICAL PROTECTIVE FILM
 -50 BLACK POWDER COATING

SPRING AND WASHER- 303 STAINLESS STEEL, PASSIVATED

O-RING- BUNA-N, BLACK

PIN- 303 STAINLESS STEEL, NATURAL

SHAFT- BUSHING ASS'Y. CONSISTS OF:

SHAFT AND PIN- 303 STAINLESS STEEL, PASSIVATED OR

BLACK ORGANIC COATING

BUSHING- ALUMINUM, PASSIVATED OR BLACK ORGANIC

COATING

MTG. LOCKWASHER- SPRING STEEL, ZINC ALLOY PLATE, BRIGHT

CHROMATE PLUS SEALER

MOUNTING NUT- BRASS, ZINC PLATE, BRIGHT CHROMATE

PLUS SEALER

LOCKWASHERS- SPRING STEEL

JAM NUTS- LOW CARBON STEEL, ZINC ALLOY PLATE, BRIGHT

CHROMATE PLUS SEALER

ACTUATOR- 1010 STEEL, ZINC PLATE, CHROMATE PLUS SEALER

GASKET- FIBRE, NATURAL

- B. THE ACTUATOR MAY BE OMITTED IF THE LATCH IS
 NOT TO BE USED AS A MULTI-POINT LATCH.

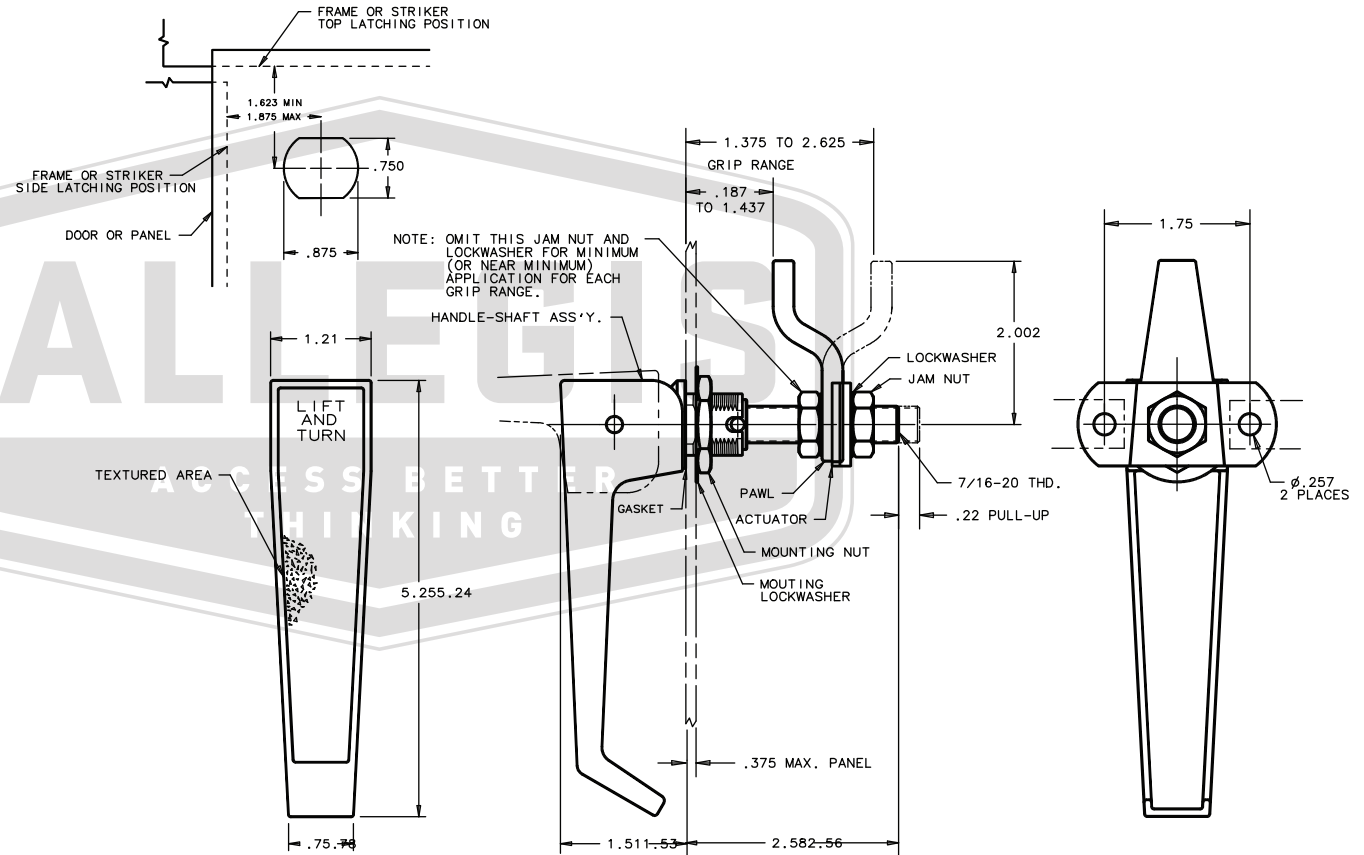

ALLEGIS	1-866-378-7550
MATERIAL: Zinc Alloy	DRAWING NO. : 62-10-603-10
FINISH: Chrome Plated	
REV.: 1:1	DATE: 5/29/2019