

APPROVAL - CUSTOMER NAME & SIGNATURE

DATE

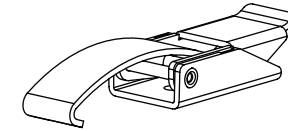

SCALE 1:1

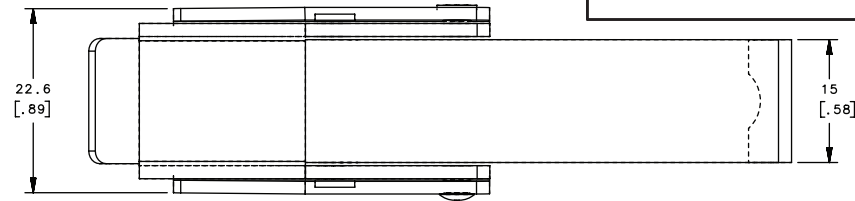
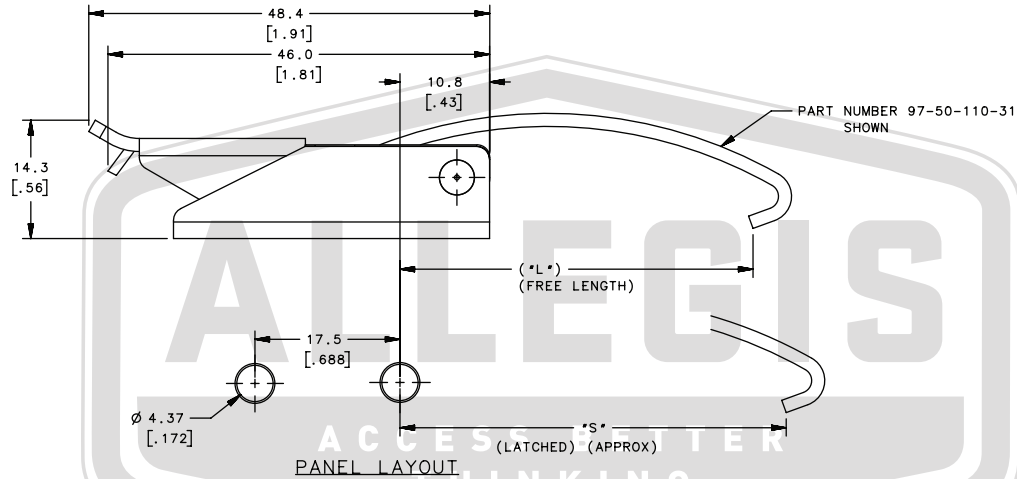

NOTES:  
A. FINISH SUFFIX 35 WOULD BE SAME AS -15, BUT WITH SPRING SUPPORT.

FINISH SUFFIX	LEVER AND BASE		LATCHING SPRING		PIN AND RIVET	
	MATERIAL	FINISH	MATERIAL	FINISH	MATERIAL	FINISH
-11	STEEL	ZINC PLATE PLUS BRIGHT CHROMATE DIP	HARDENED STEEL	ZINC PLATE PLUS BRIGHT CHROMATE DIP	STAINLESS STEEL	PASSIVATED
-12	STAINLESS	PASSIVATED	PRECIPITATION HARDENING STAINLESS STEEL	PASSIVATED		
-15	STEEL	BLACK POWDER COAT	HARDENED STEEL	BLACK POWDER COAT		
-52	STAINLESS	BLACK POWDER COAT	PRECIPITATION HARDENING STAINLESS STEEL	BLACK POWDER COAT		
-35	STEEL	BLACK POWDER COAT	HARDENED STEEL	BLACK POWDER COAT		

PART NUMBER	TYPE OF COMPONENT	LEVER STYLE	SPRING RATING	SPRING LENGTH	L	S
97-50-270-11	DRAW LATCH	ACTUATING TAB DOWN	HEAVY DUTY	LONG	54.8[2.16]	57.1[2.25]
97-50-260-11	DRAW LATCH			MEDIUM	42.1[1.66]	44.4[1.75]
97-50-250-11	DRAW LATCH			SHORT	29.4[1.16]	31.8[1.25]
97-50-230-12	DRAW LATCH			LONG	54.8[2.16]	57.1[2.25]
97-50-220-XX	DRAW LATCH			MEDIUM	42.1[1.66]	44.4[1.75]
97-50-210-XX	DRAW LATCH	ACTUATING TAB UP	HEAVY DUTY	SHORT	29.4[1.16]	31.8[1.25]
97-50-170-11	DRAW LATCH			LONG	54.8[2.16]	57.1[2.25]
97-50-160-11	DRAW LATCH			MEDIUM	42.1[1.66]	44.4[1.75]
97-50-150-11	DRAW LATCH			SHORT	29.4[1.16]	31.8[1.25]
97-50-130-12	DRAW LATCH			LONG	54.8[2.16]	57.1[2.25]
97-50-120-XX	DRAW LATCH	HEAVY DUTY	MEDIUM	SHORT	29.4[1.16]	31.8[1.25]
97-50-110-XX	DRAW LATCH			LONG	54.8[2.16]	57.1[2.25]

**ALLEGIS**

1-866-378-7550

MATERIAL:

Steel

DRAWING NO.:

97-50-120-11

FINISH:

Zinc Plate, bright chromate

REV.:

1:1

DATE:

5/29/2019