

APPROVAL - CUSTOMER NAME & SIGNATURE

DATE

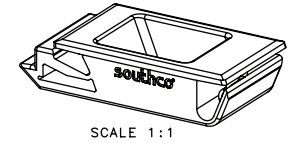

SCALE 1:1

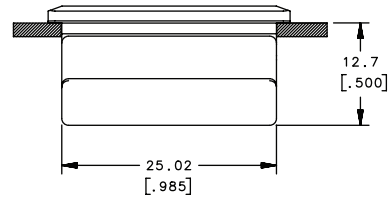
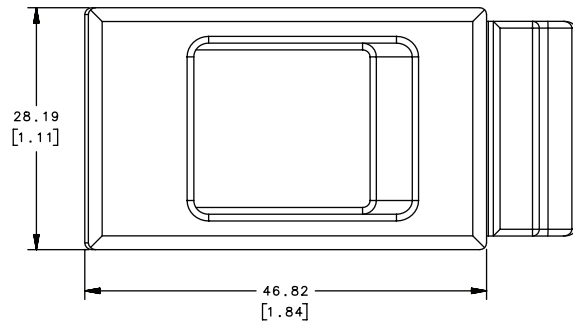
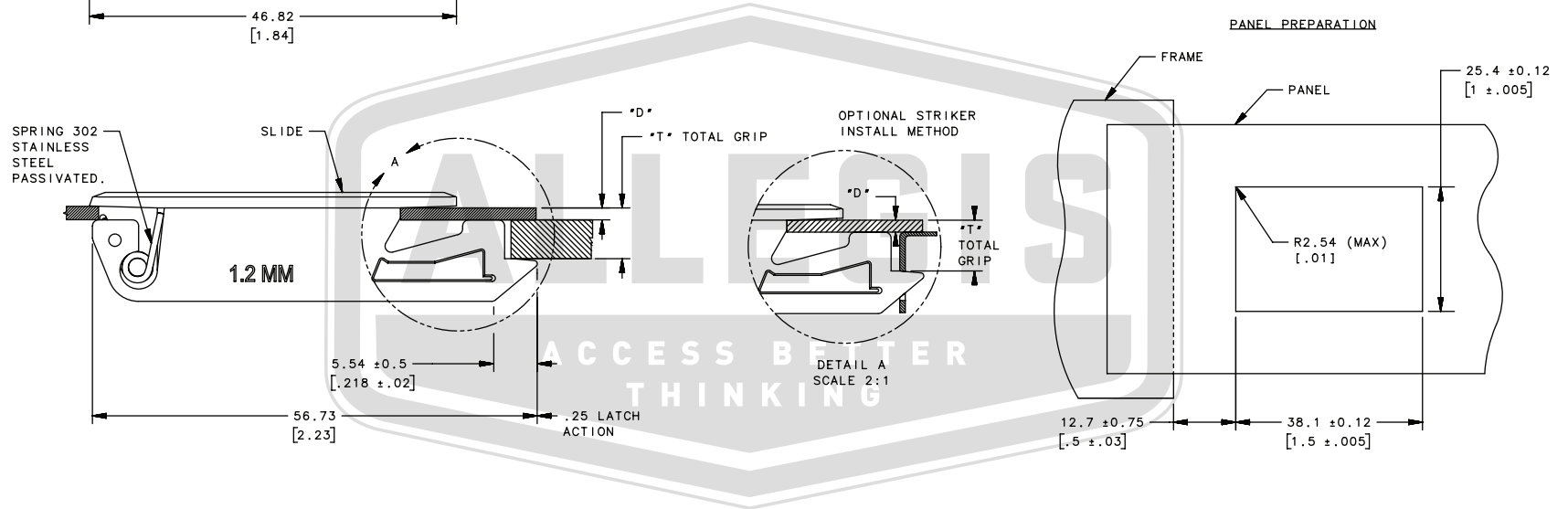

A3-40-525-22	6.35 [.250]	1.27 [.050]	ABS	GREY
A3-40-525-32	6.35 [.250]	1.27 [.050]	ABS	BLURPLE
A3-40-525-12	6.35 [.250]	1.27 [.050]	ABS	BLACK
ASSEMBLY	*T* +/-0.127 [.005]	*D* +/-0.127 [.005]	SLIDE MATERIAL	SLIDE COLOR

INSTALLATION:

1. PREPARE A BURR-FREE HOLE, AS SHOWN.
2. SLIP FRONT OF LATCH THROUGH THE HOLE AND PUSH FORWARD.
3. SNAP BACK END OF LATCH INTO POSITION.

ALLEGIS		1-866-378-7550	
MATERIAL: Plastic	DRAWING NO. : A3-40-525-12		
FINISH:			
REV.:	1:1	DATE:	5/29/2019