

APPROVAL - CUSTOMER NAME & SIGNATURE

DATE

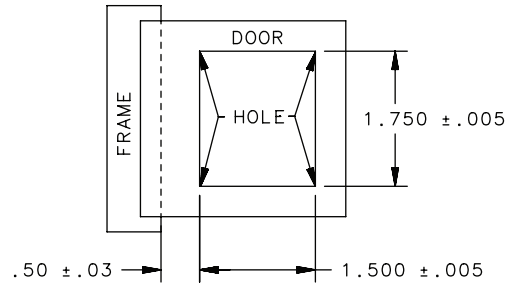

PANEL PREPARATION
SCALE 1:2

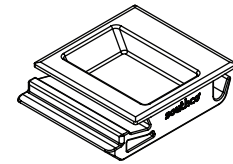

SCALE 1:2

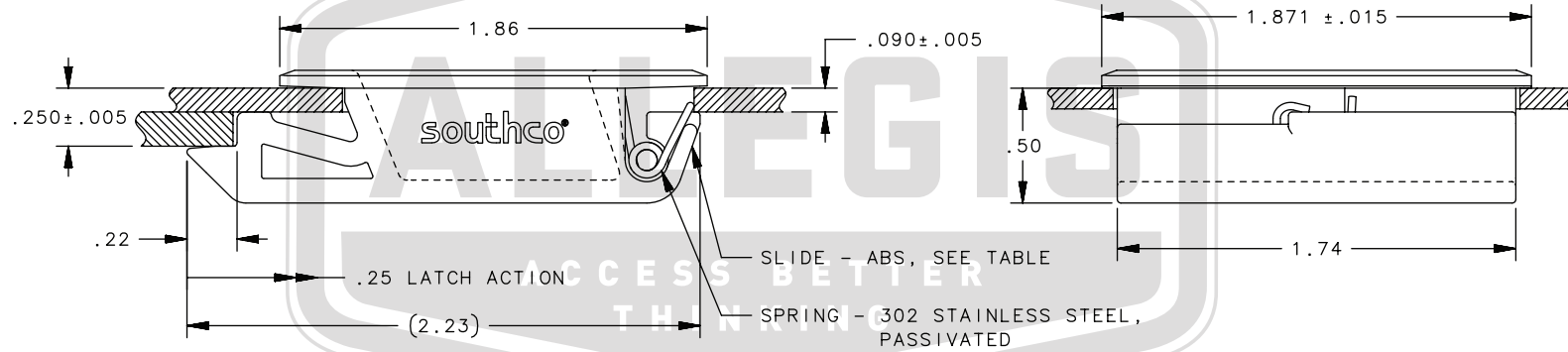

A3-50-925-23	SLIDE	MEDIUM WHITE
A3-50-925-12	SLIDE	BLACK
A3-50-925-11	SLIDE	WHITE
PART NUMBER	TYPE OF COMPONENT	FINISH

NOTES:

A. PATENT NUMBER 3,841,674.

B. INSTALLATION:

SLIDE THE FRONT OF THE LATCH
INTO THE PREPARED HOLE AND
THEN SNAP THE BACK END DOWN
INTO POSITION.

ALLEGIS

1-866-378-7550

MATERIAL:

Plastic

DRAWING NO.:

A3-50-925-12

FINISH:

REV.:

1:1

DATE:

5/29/2019