

APPROVAL - CUSTOMER NAME & SIGNATURE

DATE

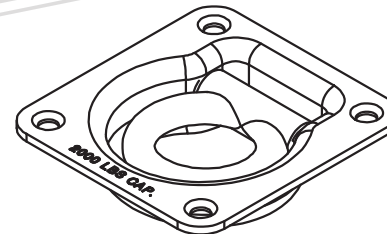
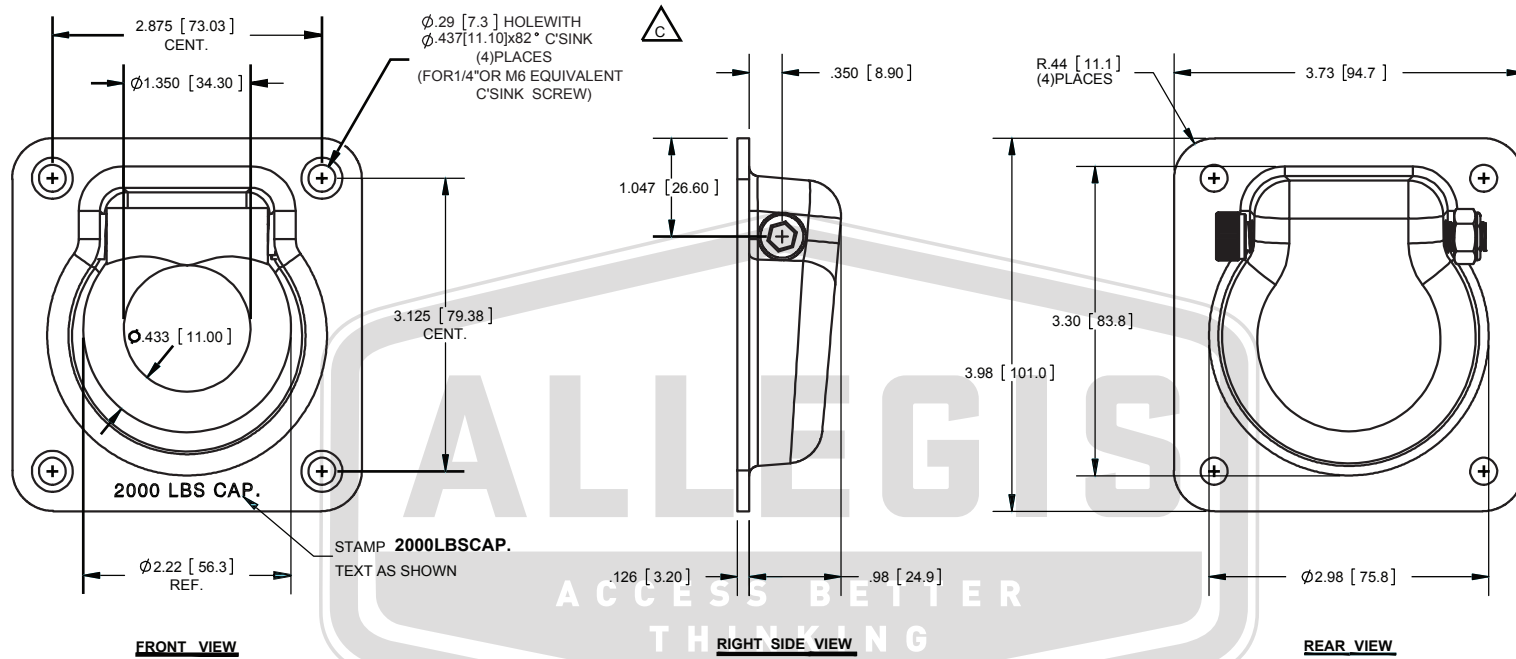

UNLESS OTHERWISE SPECIFIED:  
 DIMENSIONS ARE IN INCHES  
 TOLERANCES:  
 FRACTIONAL 1/32 ANGULAR: MACH 1°  
 BEND 1°  
 TWO PLACE DECIMAL .01 THREE  
 PLACE DECIMAL .005

<b>ALLEGIS</b>		1-866-378-7550	<b>AUTOMOTIVE TIE DOWN ASSEMBLY</b>	
MATERIAL: See Chart	DRAWING NO. : ALG 72 ____	NOTES: 1. DIMENSIONS IN BRACKETS ARE IN METRIC 2. REMOVE ALL BURRS AND SHARP EDGES.		
FINISH: Surface Finish	P/N: ALG 72 SS	Stainless Steel material/finish		
REV. : 1:1	DATE: 2-26-2020	P/N: ALG 72 ZN	Steel w/ Zinc finish	