

APPROVAL - CUSTOMER NAME & SIGNATURE

DATE

ASSEMBLY PART NUMBER TABLE		
BLACK POWDER COATED	TEXTURED CHROME FINISH	SILVER POLYESTER POWDER COATED
C2-32-35	C2-32-31	C2-32-37

- A. MATERIAL AND FINISH
1. HOUSING, LEVER AND TRIGGER: DIE CAST ZINC, SEE ASSEMBLY PART NUMBER TABLE.
 2. U-SPRING: 302 STAINLESS STEEL, PASSIVATED.
 3. TORSION SPRING: 302 STAINLESS STEEL, NATURAL.
 4. SPIROL PIN: SAE 51420, NATURAL.
 5. LOCKWASHER: SPRING STEEL, ZINC ALLOY PLATE BRIGHT PLUS SEALER.
 6. SCREWS AND HEX NUT: LOW CARBON STEEL, ZINC ALLOY PLATE BRIGHT PLUS SEALER.
 7. BRACKET: 1010 STEEL, ZINC ALLOY PLATE BRIGHT PLUS SEALER.
- B. MOUNTING SCREW ASSEMBLY CONSISTS OF: M5 SCREW WITH LOCKWASHER. USE LONGER SCREWS (NOT SUPPLIED) FOR THICKER DOORS.
- C. MOUNTING BRACKET AND SCREW ASSEMBLY PACKAGED IN PLASTIC BAG, SHIPPED UNASSEMBLED.

REV	DATE	DRAWN/CHKD	DESCRIPTION
A	14MARG4	JAD	PRN: C2-84
B	14DEC95	CHW	ADDED P/N C2-32-37
C	11OCT96	SWD	PRN: S-93-23
D	23FEB99	JDK/CHW	PRN: C2-139
E	30APR2003	VNI/MJS	PRN: P2003-0339
F	19JUN2003	RLR/MJS	PRN: P2003-0504
G	23JUL2013	MUS/TVA	PRN: P2013-1498
H	13AUG2018	OMS/LT	PRN: P2018-1902

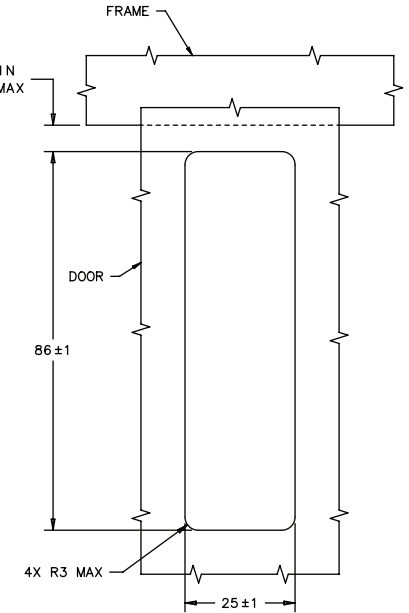
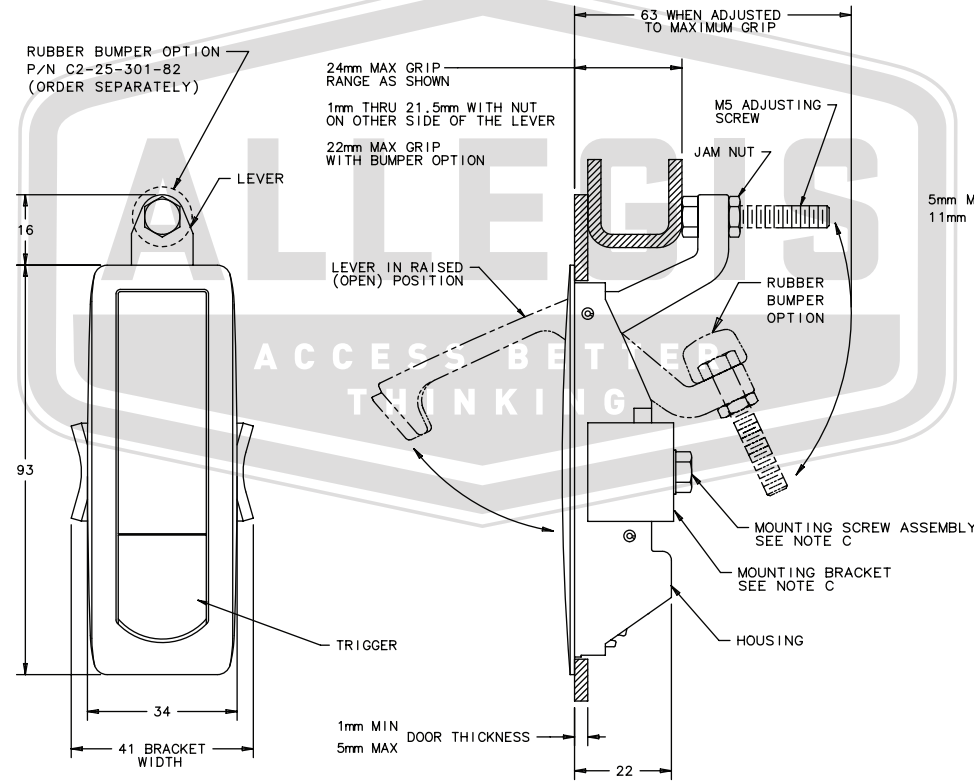

PANEL PREPARATION

ALLEGIS		1-866-378-7550
MATERIAL:	Zinc Alloy	DRAWING NO. : C2-32-31
FINISH:	Chrome Plated	
REV.:	1:1	DATE: 5/29/2019