

APPROVAL - CUSTOMER NAME & SIGNATURE	DATE

REV	DATE	DRAWN/CHKD	DESCRIPTION	ASSEMBLY	MATERIAL AND FINISH	KEEPER
A	31JUL95	MDM	PRN: K4-18	K4-2359-07	SEE NOTE A	K4-2338-07
B	03MAR2004	VNI/MJS	PRN: P2004-0221	K4-2359-77	SEE NOTE B	K4-2338-77

- NOTES:
- A. MATERIAL AND FINISH:
- ANCHOR PLATE, WING, HOUSING AND LOWER CAM: CARBON STEEL, ZINC PLATE, BRIGHT CHROMATE.
 - SLIDE: HARDENED ALLOY STEEL, ZINC PLATE, BRIGHT CHROMATE.
 - HEX CAM: POWDER METAL, ZINC PLATE, BRIGHT CHROMATE.
 - SPRINGS: MUSIC WIRE, ZINC PLATE, BRIGHT CHROMATE.
 - CAM RIVET AND CAM SPRINGS: STAINLESS STEEL, NATURAL.
- B. MATERIAL AND FINISH:
- ANCHOR PLATE, WING, HOUSING AND LOWER CAM: CARBON STEEL, ZINC NICKEL PLATE, YELLOW CHROMATE.
 - SLIDE: HARDENED ALLOY STEEL, ZINC NICKEL PLATE, YELLOW CHROMATE.
 - HEX CAM: POWDER METAL, ZINC NICKEL PLATE, YELLOW CHROMATE.
 - SPRINGS: MUSIC WIRE, ZINC NICKEL PLATE, YELLOW CHROMATE.
 - CAM RIVET AND CAM SPRINGS: STAINLESS STEEL, NATURAL.
- C. SPRING LOADED ANCHOR PLATE COMPENSATES UP TO .156 INCHES FOR MISALIGNMENT.

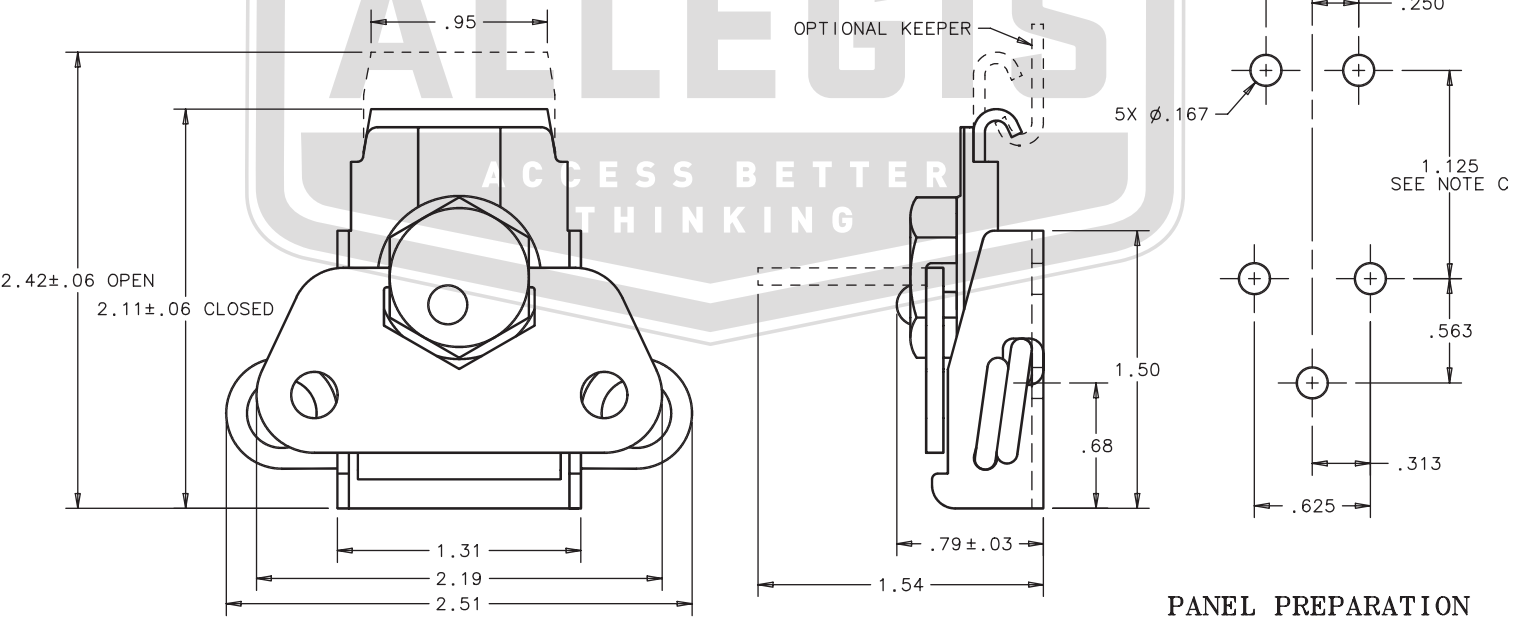

PANEL PREPARATION

ALLEGIS	1-866-378-7550
MATERIAL: Steel	DRAWING NO. : K4-2359-07
FINISH: Zinc Plate, bright chromate	
REV.: 1:1	DATE: 5/30/2019