

APPROVAL - CUSTOMER NAME & SIGNATURE

DATE

REV.	DATE	BY/CHK'D	REVISIONS
A	21MAY2001	CHW	DWG NO. WAS J-2-40-2714-07

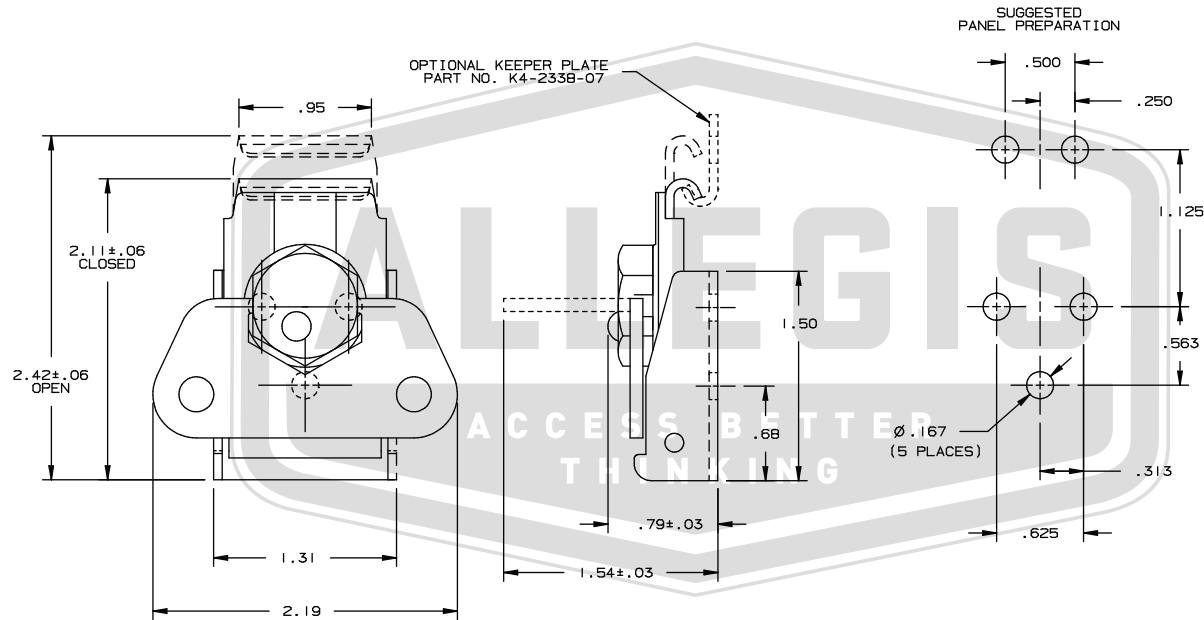

OPTIONAL KEEPER PLATE
PART NO. K4-2338-07

SUGGESTED
PANEL PREPARATION

MATERIAL & FINISH:
ANCHOR PLATE, WING, HOUSING, LOWER CAM AND ANCHOR PLATE RIVET ARE CARBON
STEEL; ZINC PLATE, BRIGHT CHROMATE DIP
SLIDE IS HARDENED ALLOY STEEL; ZINC PLATE, BRIGHT CHROMATE DIP
UPPER CAM IS POWDER METAL; ZINC PLATE, BRIGHT CHROMATE DIP
CAM RIVET AND CAM SPRING ARE STAINLESS STEEL.

DIMENSIONS
ARE IN
INCHES

DECIMAL PLACES
2 PLACE (.XX)
3 PLACE (.XXX)

TOLERANCE
± 0.015
± 0.005

ALL
ANGLES
± 1°

ALLEGIS

1-866-378-7550

MATERIAL:

Steel

DRAWING NO.:

K4-2714-07

FINISH:

Zinc Plate, bright chromate

REV.:

1:1

DATE:

5/30/2019