

APPROVAL - CUSTOMER NAME & SIGNATURE

DATE

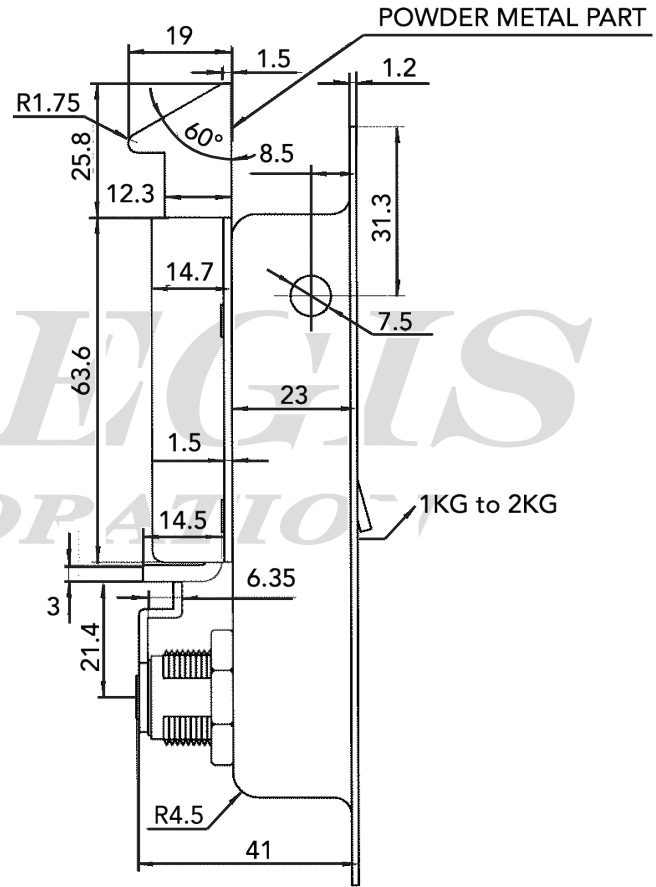
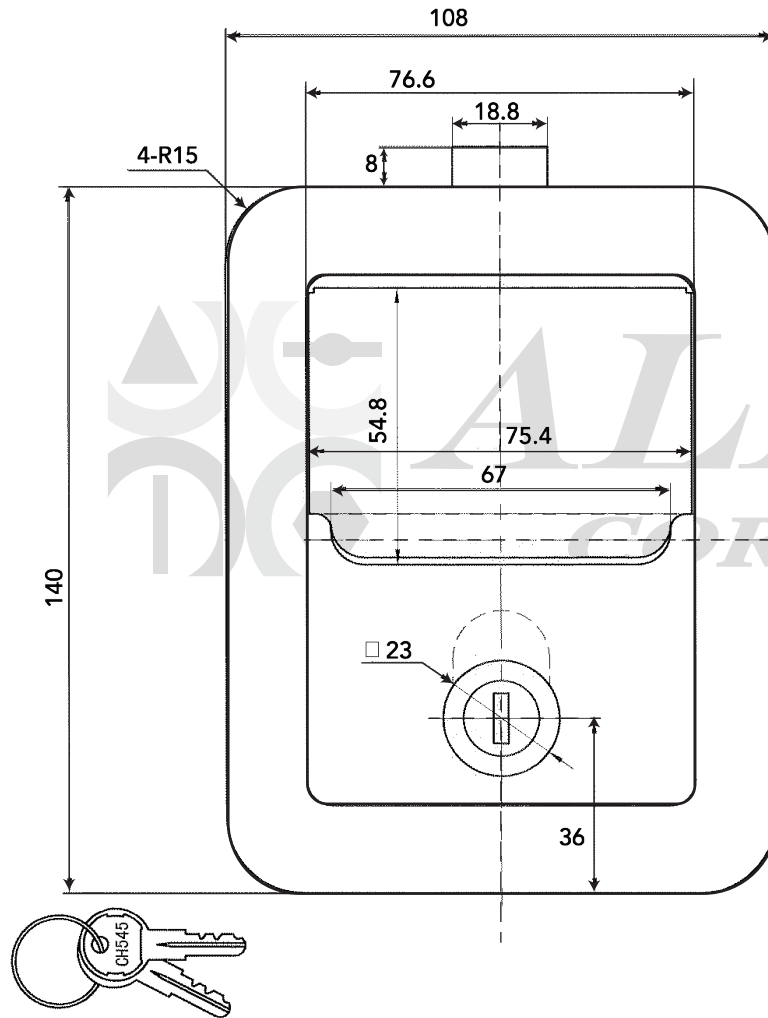

		<b>TOLERANCES FOR UNSPECIFIED DIMENSIONS</b>					
MATERIAL:	DRAWING NO. :	SIZE	A	B	SIZE	A	B
Steel	LA1001 ZN	5 under	±0.15	±0.20	250->500	±0.60	±1.00
FINISH:		5->10	±0.20	±0.30	500->750	±0.80	±1.20
Zinc plated		10->25	±0.25	±0.40	750->up	±1.20	±1.50
REV. :	DATE:	25->50	±0.30	±0.45	*A: CENTER TO CENTER		Unit mm
1 : 2	12-22-2009	50->100	±0.40	±0.60	*B: OTHERS DIMENSIONS		
		100->250	±0.50	±0.80	*ANGLE ±1.0°		