

APPROVAL - CUSTOMER NAME & SIGNATURE

DATE

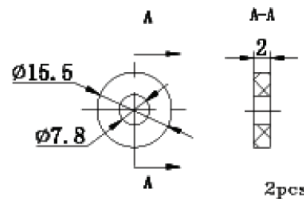
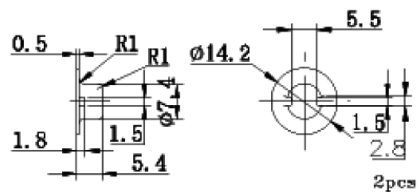
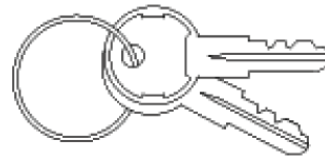
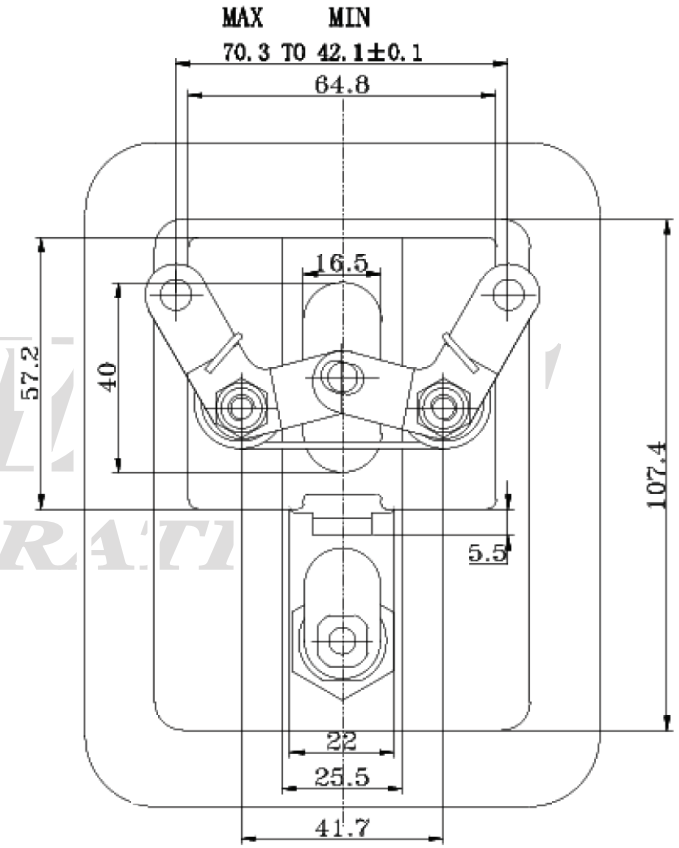
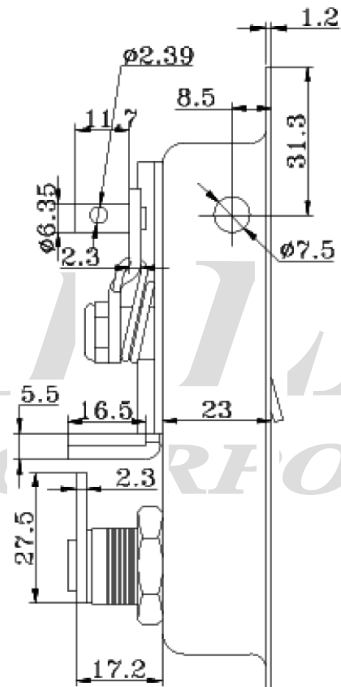
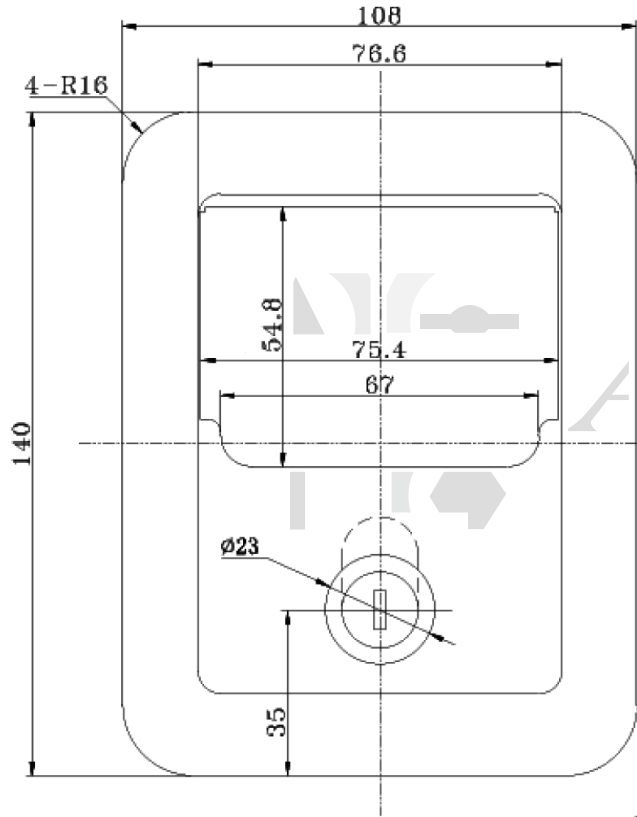

ALLEGIS CORPORATION	
MATERIAL: Steel	DRAWING NO. : LA2001 ZN
FINISH: Material Finish: Zinc plated	
REV. : 1 : 2	DATE: 2-13-2013

TOLERANCES FOR UNSPECIFIED DIMENSIONS					
SIZE	A	B	SIZE	A	B
5 under	±0.15	±0.20	250->500	±0.60	±1.00
5->10	±0.20	±0.30	500->750	±0.80	±1.20
10->25	±0.25	±0.40	750->up	±1.20	±1.50
25->50	±0.30	±0.45			
50->100	±0.40	±0.60			
100->250	±0.50	±0.80			

*A: CENTER TO CENTER
*B: OTHERS DIMENSIONS
*ANGLE ± 1.0°

Unit
mm