

APPROVAL - CUSTOMER NAME & SIGNATURE

DATE

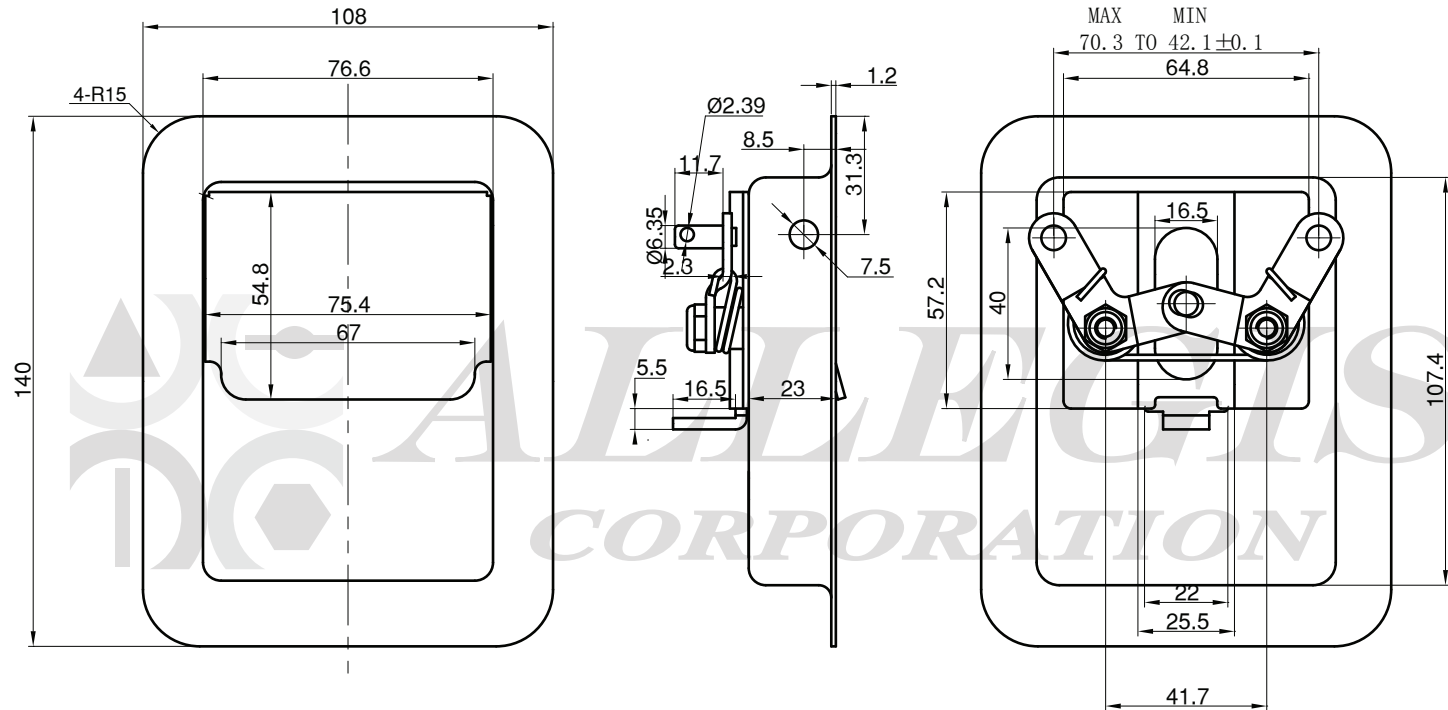

MATERIAL: Stainless Steel	DRAWING NO. : LA2003 SS
FINISH:	
REV : Comparison: 1:2	DATE: 9-3-2009

TOLERANCES FOR UNSPECIFIED DIMENSIONS					
SIZE	A	B	SIZE	A	B
5 under	±0.15	±0.20	250->500	±0.60	±1.00
5->10	±0.20	±0.30	500->750	±0.80	±1.20
10->25	±0.25	±0.40	750->up	±1.20	±1.50
25->50	±0.30	±0.45	*A: CENTER TO CENTER *B: OTHERS DIMENSIONS		Unit
50->100	±0.40	±0.60			
100->250	±0.50	±0.80	*ANGLE ±1.0°		mm