

APPROVAL - CUSTOMER NAME & SIGNATURE

DATE

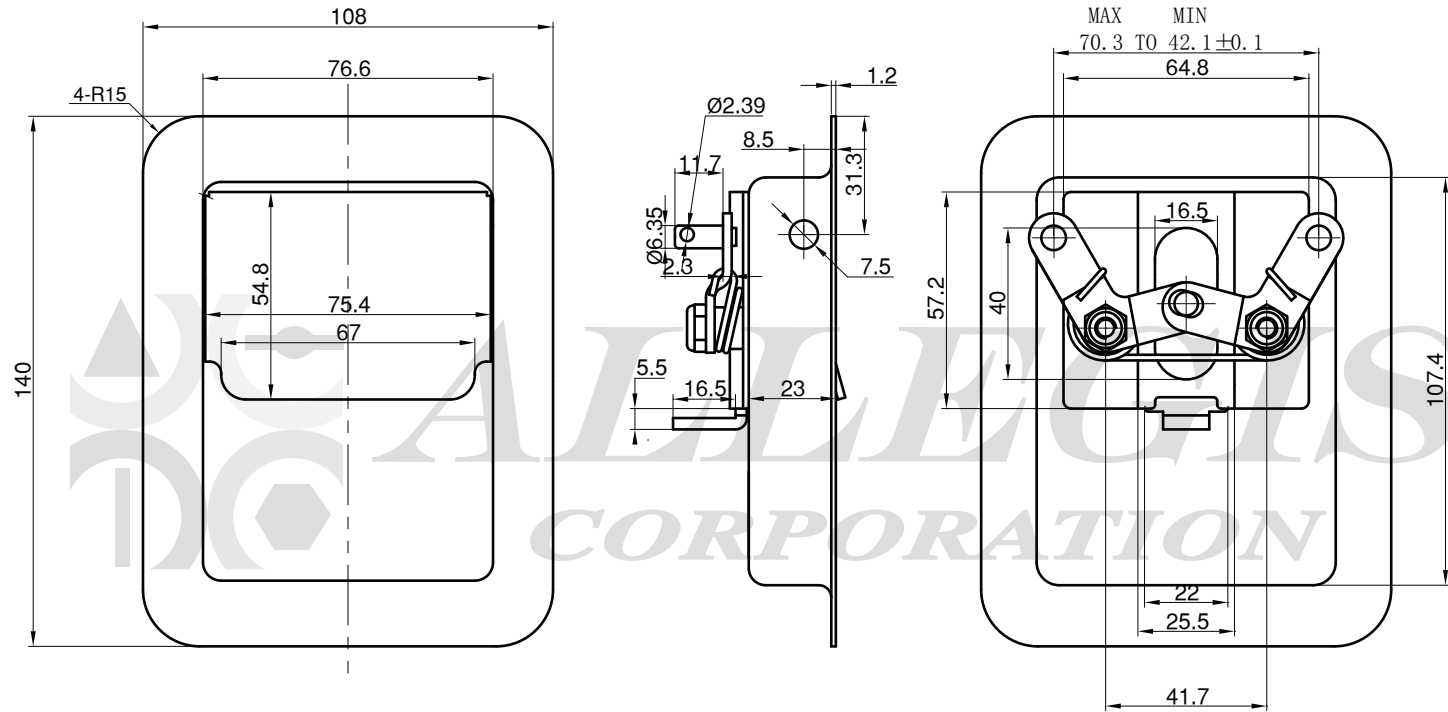

		TOLERANCES FOR UNSPECIFIED DIMENSIONS					
MATERIAL:	DRAWING NO. :	SIZE	A	B	SIZE	A	B
Steel	LA2003 ZN	5 under	±0.15	±0.20	250->500	±0.60	±1.00
FINISH:	Zinc Plated	5->10	±0.20	±0.30	500->750	±0.80	±1.20
REV.:	DATE:	10->25	±0.25	±0.40	750->up	±1.20	±1.50
Comparison: 1:2	2012-06-13	25->50	±0.30	±0.45	*A: CENTER TO CENTER	Unit	
		50->100	±0.40	±0.60	*B: OTHERS DIMENSIONS	mm	
		100->250	±0.50	±0.80	*ANGLE ±1.0°		