

APPROVAL - CUSTOMER NAME & SIGNATURE

DATE

REV.	DATE	DRAWN	REVISION	ITEM	PART NUMBER	MATERIAL	FINISH	REMARKS
G	11DEC2002	RLR/DLH	P2002-0935	ASSEMBLY	M1-43			LOCKABLE
H	19APR2004	MDY/AJH	P2004-0402	LATCH SUB-ASSEMBLY	M1-63	SEE NOTE A	SEE NOTE A	NON-LOCKING
				MOUNTING BRACKET		PC/PBT BLEND	BLACK	
				KEEPER		304 STAINLESS STEEL	PASSIVATED	
				MOUNTING SCREWS (2)		300 SERIES STAINLESS STEEL	PASSIVATED	

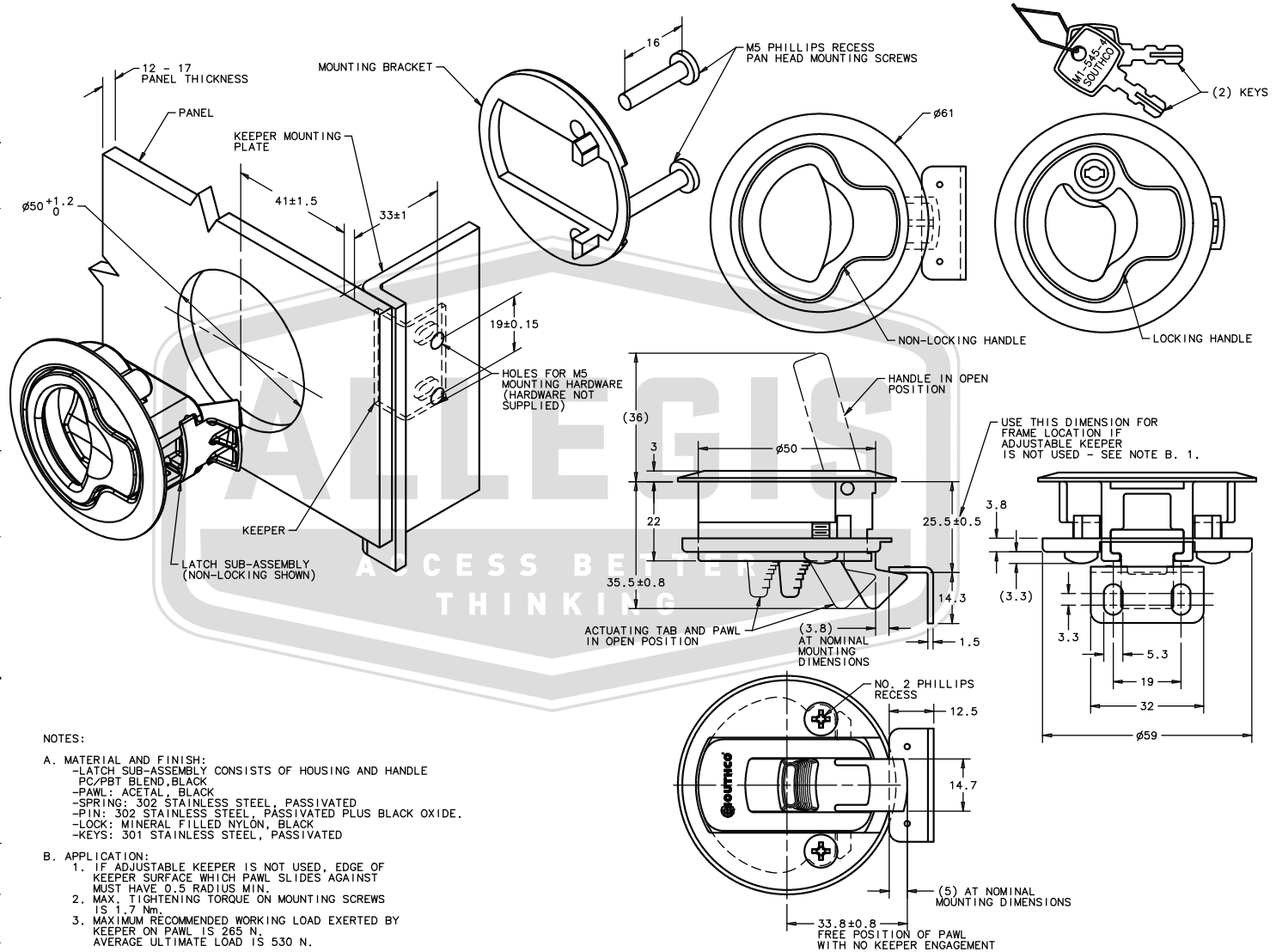

ALLEGIS	1-866-378-7550
MATERIAL:	DRAWING NO. :
Plastic	M1-43
FINISH:	
Natural	
REV.:	DATE:
1:1	5/30/2019