

Part Number	Panel Thickness	
	Min.	Max.
P2-51	1 (.040")	1.4 (.055")
P2-52	1.4 (.055")	1.8 (.070")
P2-53	1.8 (.070")	2.1 (.085")
P2-54	2.1 (.085")	2.5 (.100")

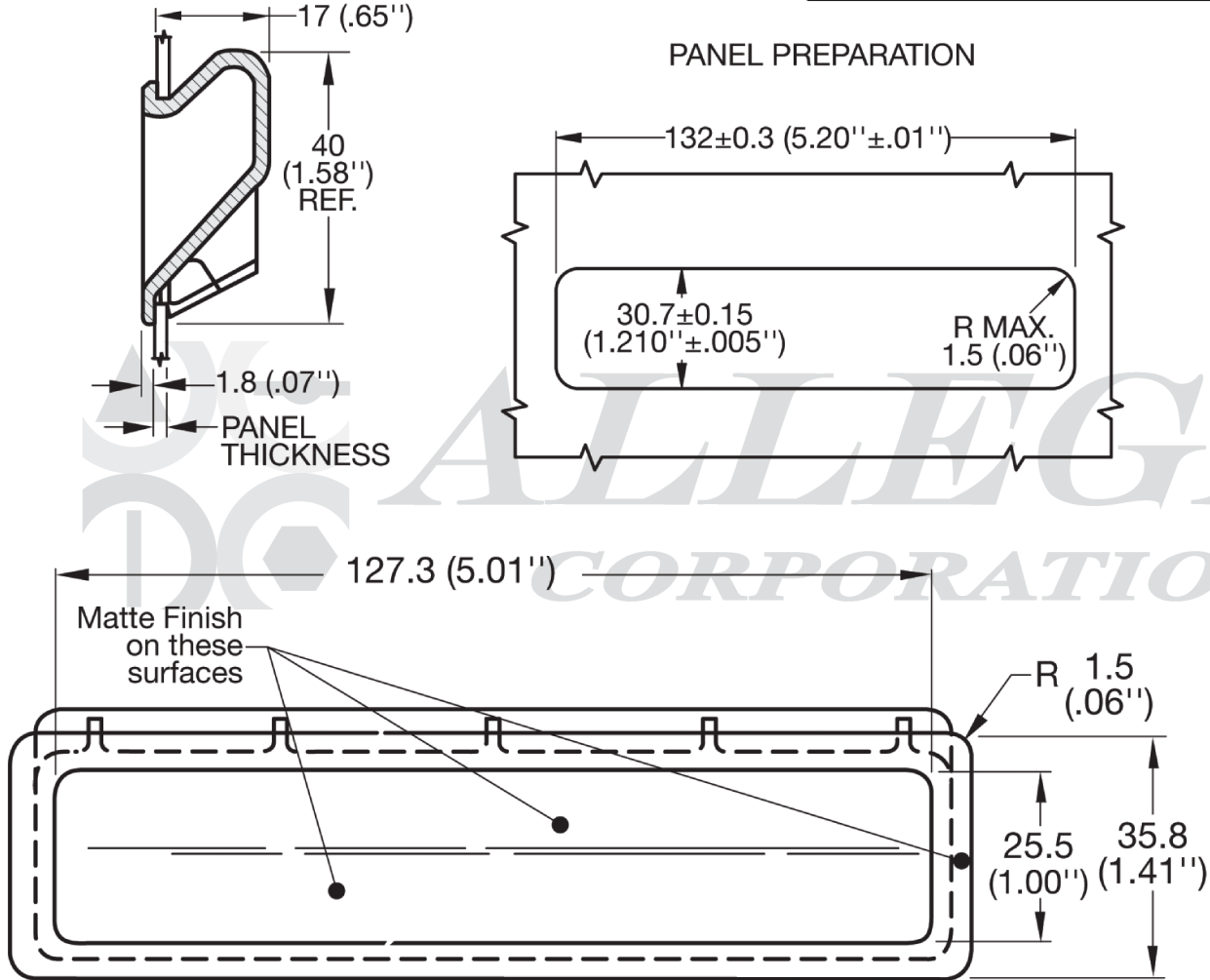

<b>www.ALLEGISCORP.com</b> <b>1-866-378-7550</b>		MATERIAL: ABS construction w/ low gloss black finish	
REV.: 1 : 1	DATE: 1-10-2013	DESCRIPTION: Pocket Pull	PART NUMBER: P2 -51 / 54