

APPROVAL - CUSTOMER NAME & SIGNATURE

DATE

N - INTERNAL THREADED

MOUNTING SCREW LENGTH = PANEL THICKNESS + 5mm
MOUNTING SCREWS NOT INCLUDED

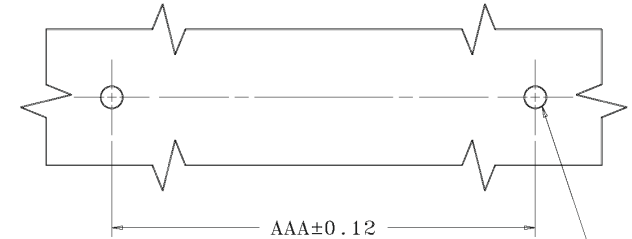
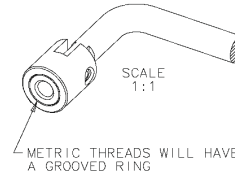
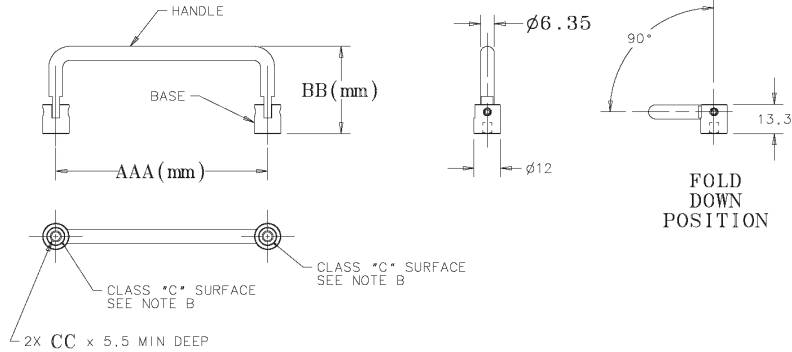

2X $\phi 3.5 \pm 0.1$ THRU FOR 4-40 & M3 SCREWS
 $\phi 4.0 \pm 0.1$ THRU FOR 6-32 SCREWS
 $\phi 4.5 \pm 0.1$ THRU FOR 8-32 & M4 SCREWS

PANEL PREPARATION
SCALE 1:1

X - EXTERNAL THREADED

PANEL THICKNESS = 8.5 MAX
MOUNTING HARDWARE INCLUDED - (2) HEX NUTS, (2) LOCKWASHERS

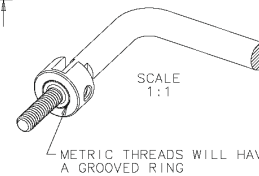
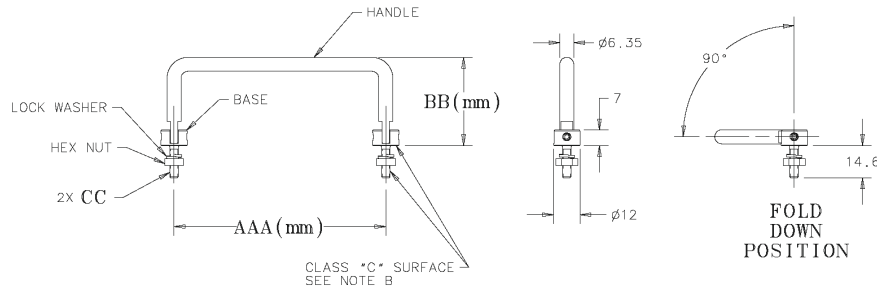

ALLEGIS

1-866-378-7550

MATERIAL:

DRAWING NO.:

P9-096-40-08N-15

FINISH:

REV.:

1:1

DATE:

6/17/2019