

5	-	1	HOUSING	SEE NOTE A	SEE NOTE A
4	-	1	CAM HALF, MALE	SEE NOTE A	SEE NOTE A
3	-	1	CAM HALF, FEMALE	SEE NOTE A	SEE NOTE A
2	-	1	HUB	SEE NOTE A	SEE NOTE A
1	R2-0055-XX	1	ASSEMBLY	SEE NOTE A	SEE NOTE A
NO.	PART NUMBER	QTY	TYPE OF COMPONENT	MATERIAL	FINISH

NOTES:

A. MATERIAL AND FINISH:

R2-0055-02

CAMS, HUB, HOUSING, AND RECEPTACLE:
CARBON STEEL, ZINC PLATED PLUS
BRIGHT CHROMATE FINISH

R2-0055-17

HUB: CARBON STEEL, ZINC PLATED PLUS
BRIGHT CHROMATE FINISH
CAM, HOUSING, AND RECEPTACLE:
G90 GALVANIZED STEEL.

ALLEGIS		1-866-378-7550	
MATERIAL: Steel		DRAWING NO. : R2-0055-02	
FINISH: Zinc Plate, bright chromate			
REV.:	1:1	DATE:	5/30/2019

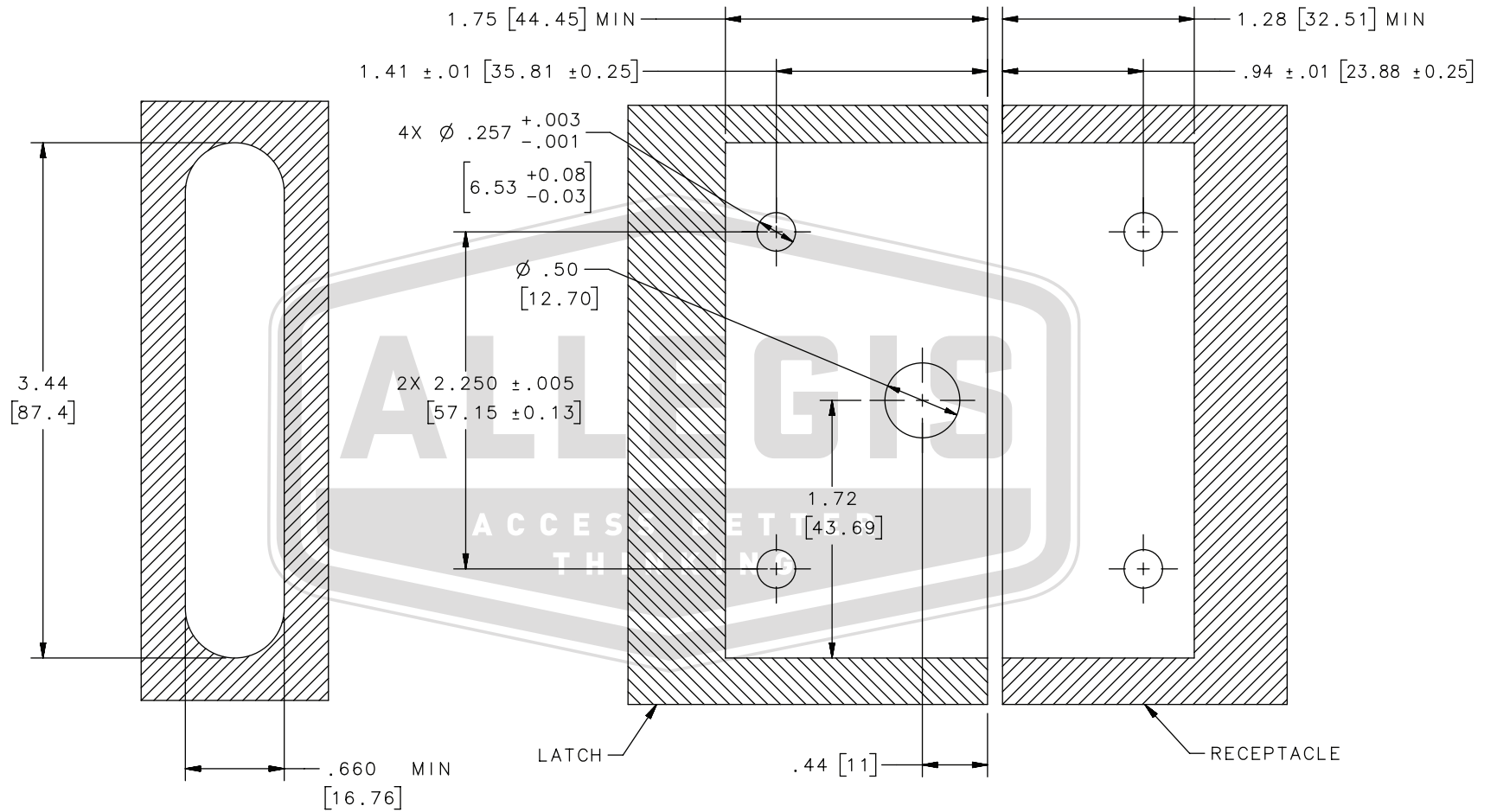

PANEL PREPARATION

ALLEGIS		1-866-378-7550
MATERIAL:	Steel	DRAWING NO. : R2-0055-02
FINISH:	Zinc Plate, bright chromate	
REV.:	1:1	DATE: 5/30/2019