

APPROVAL - CUSTOMER NAME & SIGNATURE	DATE

REV.	DATE	BY-CHKD	REVISIONS	NUMBER	MATERIAL	FINISH
				R2-0268-02	SEE NOTE "A"	SEE NOTE "A"

NOTE "A":
 MATERIAL: CARBON STEEL.
 FINISH: ZINC PLATE, BRIGHT CHROMATE DIP.

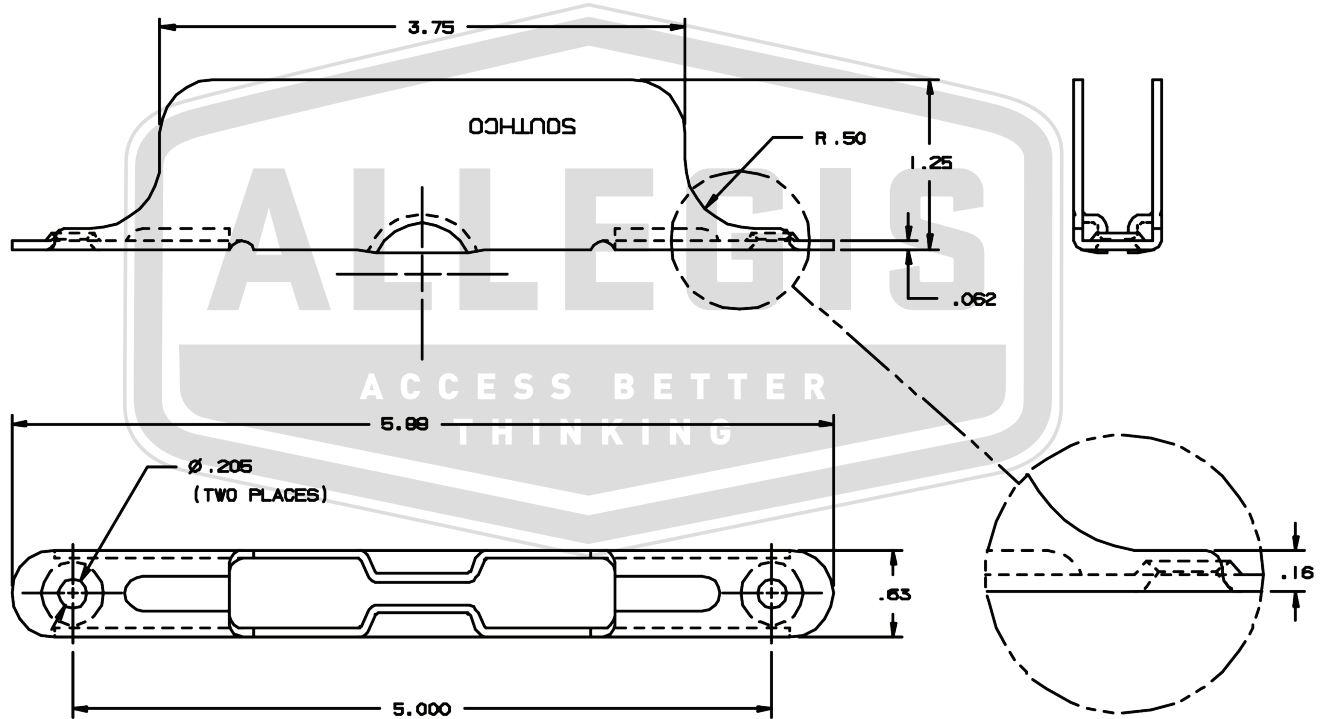

ALL DIMENSIONS ARE IN INCHES
 ALL DIMENSIONS WITHOUT TOLERANCES ARE FOR REFERENCE ONLY.
 THIRD ANGLE PROJECTION

ALLEGIS	1-866-378-7550
MATERIAL: Steel	DRAWING NO. : R2-0267-02
FINISH: Zinc Plate, bright chromate	
REV.: 1:1	DATE: 5/30/2019